

# EE Times

For the creators of technology

# europa



BEAGLE BONE

**GREEN** **V** **S** **BLACK**

A SIDE BY SIDE COMPARISON BY



**MOUSER**  
ELECTRONICS



# Best of Class: Parts in Stock Available for Immediate Shipment

Source: Distributor Evaluation Study, UBM Tech, May 2015

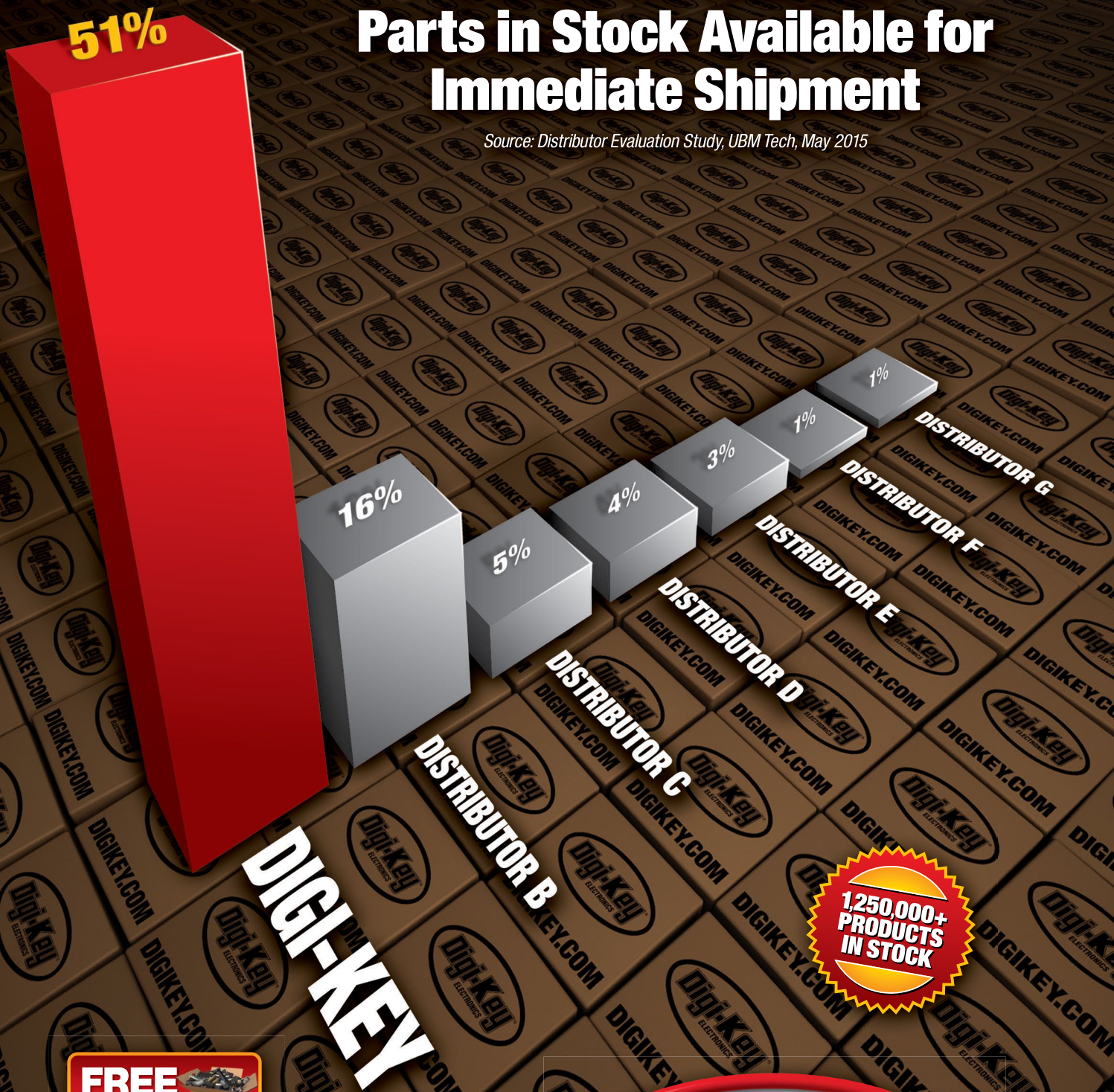

**1,250,000+  
PRODUCTS  
IN STOCK**



FIND CONTACT AND ORDERING  
INFORMATION FOR YOUR REGION AT  
**DIGIKEY.COM/EUROPE**



4.75 MILLION PARTS ONLINE | 650+ INDUSTRY-LEADING SUPPLIERS | 100% AUTHORIZED DISTRIBUTOR

\*A shipping charge of €18.00 (£12.00) will be billed on all orders of less than €65.00 (£50.00). All orders are shipped via UPS for delivery within 1-3 days (dependent on final destination). No handling fees. All prices are in euro and British pound sterling. If excessive weight or unique circumstances require deviation from this charge, customers will be contacted prior to shipping order. Digi-Key is an authorized distributor for all supplier partners. New product added daily. © 2016 Digi-Key Electronics, 701 Brooks Ave. South, Thief River Falls, MN 56701, USA



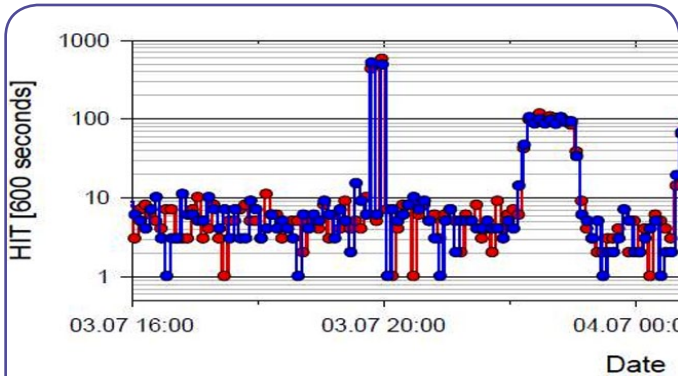

## 4 & 49: OPINION

**Uncommon Market:**  
Space radiation detectors get personal

**Last Word:** Maintaining a competitive edge in 2016

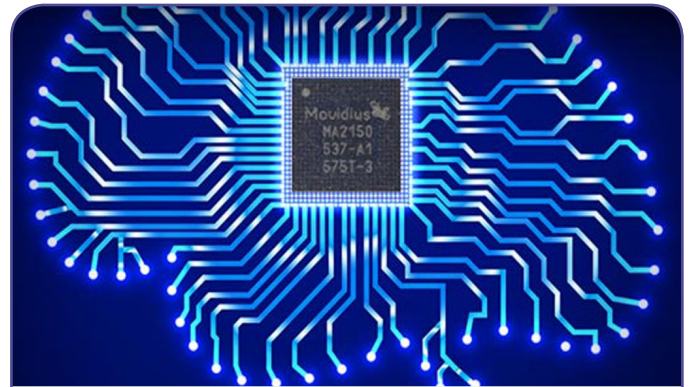

## 6 - 23: NEWS & TECHNOLOGY

In a new agreement with Google, startup Movidius intends to bring super intelligent models—extracted from deep learning at Google’s data centers—over to mobile and wearable devices.

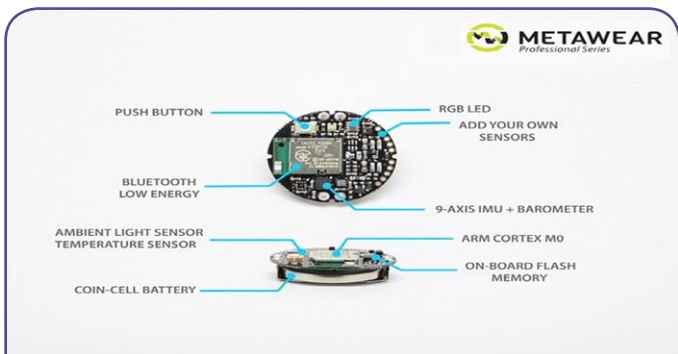

## 24 - 31: PROTOTYPING & DEV BOARDS

With the CPRO version of its MetaWear sensing platform, Californian startup mbientlab is providing makers a Bluetooth-connected remote sensor on steroids.

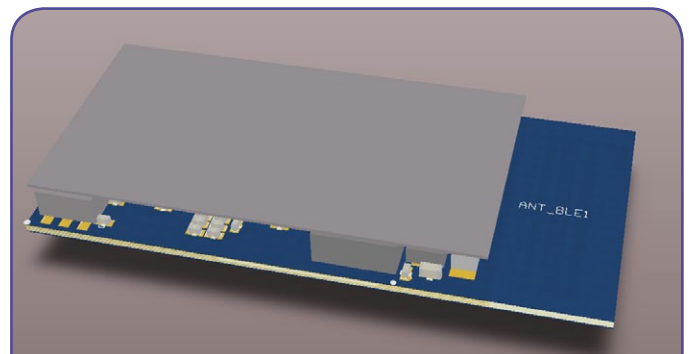

## 32 - 39: WIRELESS COMMUNICATIONS

Renewed interest in UWB for precise distance measurement and indoor positioning. Has the technology found a niche that it can really claim as its own?

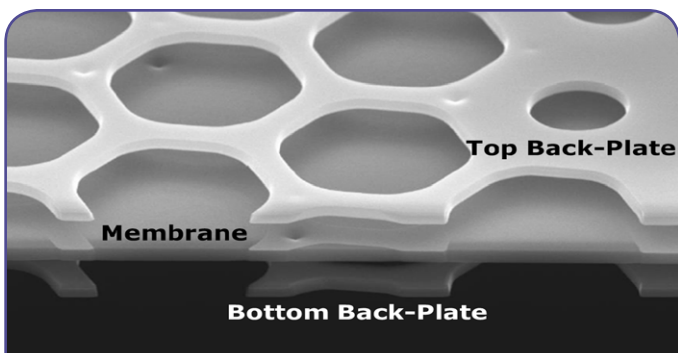

## 40 - 45: MEMS TECHNOLOGIES

Placing the moving membrane between two capacitor plates to produce a differential output, Infineon’s dual back-plate MEMS microphone minimizes distortion and is more readily managed through the audio processing chain.

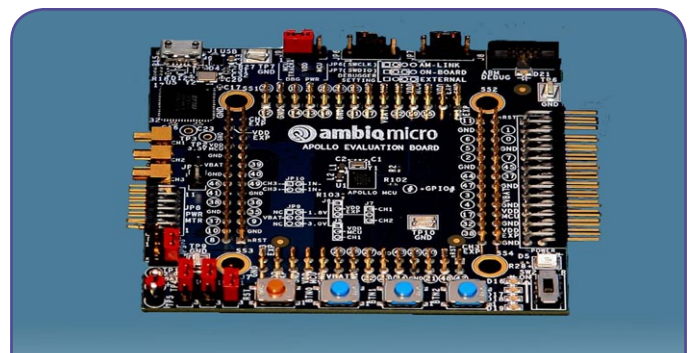

## 46: READER OFFER

This month Ambiq Micro is giving away five of its ‘Apollo EVB’ evaluation boards, worth \$249 each for EETimes Europe’s readers to assess the capabilities of its Apollo sub-threshold microcontroller.

## 48: DISTRIBUTION CORNER

## Space radiation detectors get personal

By Julien Happich

In the harsh environment of space, astronauts are exposed to many dangers – including the possibly harmful health effects of radiation exposure. While previous radiation detectors

have only revealed how much exposure an astronaut had received after their return to Earth, a team of European researchers has developed an active and wearable radiation monitor that can measure radiation in real time and instantly warn astronauts of increased and dangerous radiation levels.

The personal radiation dosimeter system is made up of two parts: a phone-sized Mobile Unit, worn in a pouch on the astronaut's body, and a Personal Storage Device, which is a docking station to recharge the Mobile Unit, download data and transmit it back to Earth.

Measuring 93x58x17mm, the mobile unit is specified to operate in excess of a week on one battery charge (10.5 days nominal) and can display the astronaut ID, the mission dose and the dose rate. It has recently returned from testing on the International Space Station, and in a world-first event, it actively monitored radiation during its launch into space on board the Soyuz spacecraft. The system was developed as a result of the EuCPAD (European Crew Personal Active Dosimeters) project.

A small team at Cork's Tyndall National Institute led by Dr. Aleksandar Jaksic of Tyndall's Devices and Systems for Radiation Dosimetry, in close co-operation with the institute's semiconductor fabrication plant, developed, fabricated and supplied three of the four different types of radiation sensors that make up the mobile unit. Each sensor covers a different type or spectrum of radiation to give a comprehensive picture of the radiation environment in space, which is more complex and harder to measure than that on Earth.

The EuCPAD allows researchers to know at all times what the radiation level is and compare them to radiation received in different modules of the space station as well as look at the effects of a Solar Particle Events for example.

"Currently astronauts use radiation detection devices that are

passive and only get analysed on their return to tell them what radiation dose they received. If a catastrophic radiation event happens, like a solar flare, they will not know about it in time to

protect themselves and hide in more shielded modules of the ISS. But this device, which can be worn in a pocket, shows the radiation levels in real time and can alarm astronauts if the dose goes above a certain threshold. In addition, it enables a time resolved personal radiation record for each astronaut", explained Dr. Jaksic.

"Designing the general concept of the instrument was the first challenge, as it needed to fully cover a complex radiation spectrum in space. For this reason, the MU comprises four sensors (thick silicon diode, thin silicon diode, Instadose, and RADFET). Then the sensors needed to be made to stringent requirements, including very good control of design parameters (junction depth/capacitance), low noise (leakage current), and repeatability [this was Tyndall's main responsibility]. The next challenge was comprehensive characterisation in the variety of radiation fields. Finally, system integration and tests to ESA/ISS standards were the last very demanding step", continued Jaksic by email.

For the research centre, the next step could be to apply the developed technologies and concepts to dosimetry in terrestrial applications, such as radiation workers' health and safety, personal dosimetry for first responders or the general population, and possibly the design of miniaturised radiation detectors built in mobile phones, or as wearables.

"Tyndall will be actively pursuing these goals with the RADFETs and diodes developed during EuCPAD", concluded the

researcher.

Participants to this European Space Agency-sponsored collaborative project also included the German Aerospace Centre (DLR, project co-ordinator), RADOS/Mirion of Finland, Seibersdorf Laboratories of Austria, and PTB of Germany. The radiation monitor will be placed permanently on the ISS in June 2016.

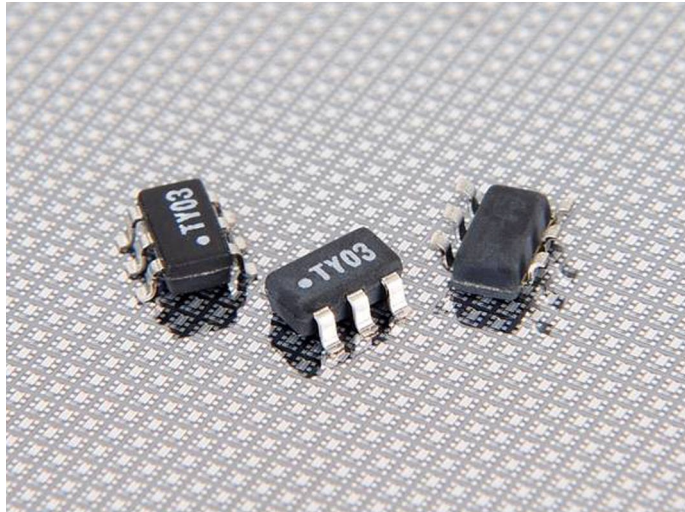

On top of a RADFET wafer, the RADFET chips designed at Cork's Tyndall National Institute.



Left, a mobile unit, and right the docking station.

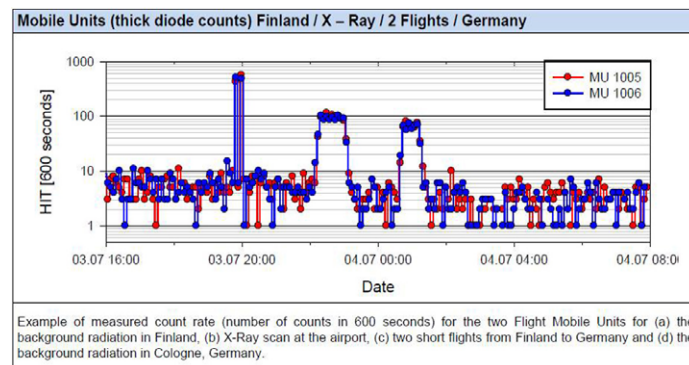



If your 5G idea works here...



it will work here.

50,000 football fans streaming live-action mobile video. All at once.

Soon it will be reality. A world connected as never before. Always on. Amazingly fast. Massive traffic. Instant information. That's the promise of 5G. New spectrum. New waveforms. Millimeter-waves. Massive MIMO. More. Keysight offers the world's first 5G simulation, design and test environment able to emulate your real-world 5G wireless thesis. With deep expertise to help you tackle 5G risk and complexity. So you can go from 5G ideas to 5G reality faster.

**HARDWARE + SOFTWARE + PEOPLE = 5G INSIGHTS**

**5G** Get the latest app notes,  
white papers and tutorials  
[www.keysight.com/find/5G-Insights](http://www.keysight.com/find/5G-Insights)

 **KEYSIGHT**  
TECHNOLOGIES

Unlocking Measurement Insights



# FDSOI carries on despite ST re-org, says COO

By Peter Clarke

**S**TMicroelectronics' withdrawal from the set-top-box business and the transfer of engineers to microcontroller and digital automotive work will not stop the adoption of fully-depleted silicon-on-insulator (FDSOI) manufacturing process, according to Jean-Marc Chery, ST's chief operating officer.

Set-top box and home gateway are application areas where STMicroelectronics has already designed ICs for implementation in the FDSOI process that it has championed in the industry, albeit with limited take-up so far.

However, the news that ST is withdrawing from those markets and will make no further designs for that sector should not be seen as a blow to prospects for FDSOI, Chery told *EE Times Europe*. Indeed Chery says ST is preparing to make microcontrollers on 28nm FDSOI with options on an embedded non-volatile memory still open, but with phase-change memory as a leading contender.

Of the re-organization that eliminated the digital products group that Chery had led, he said: "This absolutely does not impact FDSOI. What is important is that, from the first figure of merit, FDSOI can provide processor cores, usually ARM processor cores, at very low operating voltage. The second figure of merit is in RF for communications. Together this makes FDSOI perfect for the Internet of Things." He added that its radiation immunity also makes it well suited for automotive applications as well as for space and defence ICs. "It has already been announced that the EyeQ4 processor from Mobileye NV will be in FDSOI and NXP/Freescale is using FDSOI for ADAS (autonomous driver assistance systems)," he said.

Chery emphasized that, following the announcement of ST's withdrawal from STB and home gateway markets and of a proposed redeployment of 600 engineers, the company is now focused on automotive and Internet of Things applications and that therefore FDSOI is a core manufacturing process. Indeed it could be argued that moving engineers familiar with FDSOI from the STB group into MCUs and automotive will help to proliferate the technology through the company.

The reason for the exit from STB is excessive competition in Asia from the likes of M-Star and also in the US while the R&D costs to serve that market remain high as they demand leading-edge and highly integrated circuits, Chery said.

On the microcontroller front Chery said: "We have announced our first MCU on 40nm bulk CMOS ramping over the next few quarters. We are developing the next node on FDSOI at 28nm. For flash [non-volatile memory] we have a couple of options. Clearly the best choice is PCM [phase-change memory]. We are looking forward to very ultra-low power MCUs."

Moving MCUs over to FDSOI at the 28nm node is an approach that is also being considered at NXP Semiconductors NV.

It may seem rash to nominate PCM as an embedded memory option when stand-alone PCM has proved problematic for decades and is continuing to cause problems for Intel and Micron in its latest incarnation known as 3D-XPoint memory. "We have another option," said Chery but he declined to state whether that was resistive RAM or perpendicular magnetic RAM, two options being considered by NXP.

But despite such plans for the medium term, the company has hit a downward spiral of declining sales, which could be hard to break.

ST announced fourth quarter 2015 sales were \$1.67 billion, down 8.8 percent year on year and the outlook for 1Q16 sales is for a 3 percent sequential decline. Although ST outsources much of its high-end digital manufacturing it retains manufacturing capacity for mixed-signal, specialty processes and such things as MEMS. Low utilization of that in-house manufacturing

capacity is contributing to pressure on profit margin.

Carlo Ferro, ST's chief financial officer, said in an analysts' call to discuss the financial results: "We need \$1.8 billion per quarter for the manufacturing machine to be comfortable."

So where will those increased sales to turn back the tide come from for ST?

"From all three of our [new] business groups," said Chery. He said that transferring engineers from STB design to MCUs would allow the company to proliferate parts, create more software and development boards and accelerate design wins.

"The second growth driver is sensors although that is still in transition mode but with good confidence to get back to growth," said Chery. "The third is specialized imaging sensors; the fourth is BCD manufacturing process and another is digital for automotive."

Going back to microcontrollers where STMicroelectronics has been a force, it is noticeable that recent mergers such as NXP, Freescale and Microchip, Atmel, will contrive to push ST down the ranking of suppliers. The merger and acquisition spree that the industry has been on has largely passed a pre-occupied ST by. Does it now need to engage with that to regain some critical mass in the automotive, industrial and IoT sectors it wants to pursue?

In answer Chery said that ST has looked for and continues to look for M&A opportunities but that transferring 600 engineers into the MCU and digital business unit is a similar yet superior approach. "This is much better than a merger. We are moving 600 people in R&D and product support but without the issues of managing corporate culture. Basically we are transferring resources from difficult markets to growth markets."



Jean-Marc Chery, COO of ST.



# Higher. Wider. Faster. Test solutions for 5G.

The next major step beyond LTE/LTE-Advanced (4G) sets challenging requirements. Rohde & Schwarz is a world leader in all areas of RF and microwave test and measurement equipment. As a technology expert, we have been actively involved in mobile communications since the first generation. We are committed to supporting the wireless communications industry with the solutions needed to investigate, develop and standardize 5G.

Check out our test solutions at [www.rohde-schwarz.com/ad/5G](http://www.rohde-schwarz.com/ad/5G)

Visit us at  
Mobile World Congress,  
hall 6,  
booth 6C40 and 6B50





# Bosch business fires on almost all cylinders

By Christoph Hammerschmidt

**W**ith overall sales exceeding €70 billion (about \$ 76 billion), the Bosch group achieved a growth of about 10 percent in 2015. Accounting for 60 % of sales, the automotive business outgrew all other business segments. And the diesel technology? Is actually a contribution to clean the air, says Bosch CEO Volkmar Denner.

Despite weak growth in the worldwide automotive industry as Bosch's most important customer, the company's Mobility Business segment achieved a growth of 12 % to reach 41.7 billion. Particularly successful product groups were fuel injection systems (gasoline as well as diesel), driver assistance systems and infotainment systems.

For the future, Bosch CEO Volkmar Denner expects particularly high demand from the electrification of the mobility. Having acquired US-based battery technology company Seeo Inc. in 2015, Bosch believes to have future-oriented expertise in the area of innovative solid-state battery cells. Another segment to which Bosch pins its hopes is electric and electronic equipment for two-wheelers as well as for commercial vehicles. For both market segments, the company has recently launched focused business units.

According to the company, the three big trends of mobility – automation, electrification and connectivity – will also have significant influence to the design of two-wheelers and commercial vehicles: For commercial vehicles, the increasing automation will help to reduce accidents. In two-wheeler segment, electronic fuel injection systems are expected to displace the carburetors. This will help to reduce fuel consumption as well as exhaust emission. In emerging markets, the changeover from traditional carburetors to electronic injection is a large business.

At the opportunity of the presentation of the annual results, Denner highlighted Bosch's position in the ongoing diesel discussion. He stressed the low CO<sub>2</sub> emission of this type of engine, saying "only with diesel engines it will be possible to reach the European Union's ambitious CO<sub>2</sub> goals." Even in the discussion about air quality and particulate matter, "diesel technology is a part of the solution, not a part of the problem", he said, adding that with adequate filter technology, it would even be possible to clean the air in large cities. "The diesel engine actually is an air cleaning engine".

The Internet of Things is currently changing Bosch's business in a dramatic way. Bosch claims to be the only market player worldwide to be active on all three levels of the IoT: Sensors, software and services.

Nevertheless, the optimisation potential of diesel engines is far from being exhausted, Denner said. According to the Bosch CEO, the technology is available to minimise the NO<sub>x</sub> emission of the compression-ignition engine. In the context of the ongoing VW exhaust gas scandal discussion, Denner said he advocates the introduction of "realistic" test procedures and test cycles, including exhaust measurements in real driving.

Not all of Bosch's four business segments were equally successful, though. While the company's Energy and Building Technology segment achieved a growth rate of 11 percent, driven mostly by industrial security solutions and smart heating products.



In strong demand were electric tools and home appliances like a product line of stoves with internet connectivity. Thus, Bosch's Consumer Goods segment grew 9.3 percent and reached sales of €17.3 billion.

Less successful was the Industrial Technology segment. Soft demand from the global machine tool industry causes sales in this business to drop 1.7 percent to €6.6 billion.

For the year ahead, Denner provided a rather cautious outlook. The company still expects an overall growth albeit at reduced speed of just 2.8 percent. Sources of strong revenue are expected to be "connected everything" – mobility, industry, energy systems and buildings. "Only with connected technologies we can meet the challenges of the future such as shortages of resources and urbanisation. To make connected solutions successful, the technology must be easily and intuitively to use. For this reason, the company will focus on factors like user experience and usability.



# Stay cool, be **MAPI!**



embedded world Hall 2 Booth 451

**#coolMAPI**

*WE speed up  
the future*

The WE-MAPI is the world's smallest metal alloy power inductor. It's efficiency is unmatched. Available from stock. Samples free of charge. For further information please visit:

[www.we-online.com/WE-MAPI](http://www.we-online.com/WE-MAPI)

Design your DC/DC converter in **REDEXPERT**, the world's most precise software tool to calculate AC losses.

- highest current ratings
- lowest AC losses in class
- incredibly low DCR
- excellent temperature stability
- innovative design
- lowest EMI radiation

The full  
WE-MAPI range:

  
 1.6x1.0    2.0x1.0    2.5x0.6    2.5x0.8    2.5x1.0    2.5x1.2    3.0x1.0    3.0x1.2    3.0x1.5    3.0x2.0    4.0x2.0

# Does your car need to know everything about you?

By Christoph Hammerschmidt

**T**oday, cars collect a huge amount of data – including personal information that allow conclusions on the driver's private affairs. Long a discussion has begun about privacy in the connected car. A Fraunhofer research project is now trying to devise solutions that protect the driver's privacy without inhibiting commercial utilisation.

Connected cars today send data to vehicle manufacturers, garages, insurance companies and spare part providers. These data are the basis for many new applications and business models. However, surrendering such data to sometimes unknown third parties poses risks endangers privacy protection. With the recently launched project SeDaFa, the Fraunhofer

Institute for Secure Information Systems (SIT) is aiming at a solution to solve these problems. The guiding principle is enabling the driver to determine who can access which data.

Many electronic units in the vehicle store and transmit data, enabling new solutions to increase the drivers safety and comfort. The downside is that they sometimes can also be used against the driver: Data on braking behaviour or driving speed can tell a lot about the drivers preferences. Insurances who have access to these data can offer a more favourable tariff or more unfavourable, depending on the data. Employers can monitor who, how and where company cars are driven. Many scenarios are conceivable that affect the drivers personal privacy. In Germany, this is subject to public discussion; as recently as this week the automotive industry association VDA has signed an agreement



with data protection offices that establishes certain rules on how to handle privacy data in and from the car.

The goal of the SeDaFa project is developing solutions that on one hand protect privacy-relevant data while on the other hand enabling OEMs and third parties to develop applications that make use of these data. The solutions will inform the driver in a transparent way about which data have been sent and for which purposes they can be used. Based on these informations, drivers will be able to decide themselves which data they want to disclose. Towards this end, the project brings experts from multiple disciplines to the table.

Initially we investigate all data streams from control units, telematics devices, sensors and infotainment systems and where they go to, explains Christoph Krau, coordinator of the SeDaFa project and department manager at the Fraunhofer Institute for Secure Information Technology. In the next step we analyse which consequences this can have to the driver and whether the data contain personal details or not.

Data on speed, for example, allow interested parties to investigate where exactly the driver moved simply through information on road conditions, traffic lights, crossroads etc, even if these data do not contain any navigation data. Within the project, the experts develop concepts how a customer can reveal insights to vehicle data without affecting his privacy. An example is wearing parts: Parts suppliers have an interested in knowing how fast certain parts wear away. For this purpose, it is possible to attach random data to the drivers data so that not the exact driving behaviour of a person is transferred but instead an average value that does not affect the wear prediction.

# Gas pedal provides haptic feedback

By Christoph Hammerschmidt

**I**f you are alone in your car on the highway and you suddenly feel a gentle vibration in your right foot, you are not gone crazy. Instead, you probably drive a car equipped with Bosch's active gas pedal. The purpose of the vibration is warning about sharp bends ahead – or just about driving too speedy.

Bosch has developed a technical aid that helps drivers travel safely and at the same time save fuel. Connected to the navigation system or road sign reading assistant, the gas pedal gives drivers a haptic warning signal if they are exceeding a speed limit, approach a sharp bend at too high speed or, more general, tend to drive with a "lead foot", burning too much fuel.

This kind of feedback to the driver's accelerator foot helps to reduce fuel consumption by as much as seven percent, the company says. This is possible because the smart pedal is linked to other automotive functions such as the transmission. In addition, it comes with the option of a palpable indication of the best time to shift gear. "The pedal tells the driver when the economy and acceleration curves intersect",

## Drive clever with an active gas pedal

Via the cloud, the vehicle receives a warning about a tight bend ahead. The pedal starts to vibrate to draw the driver's attention to it.

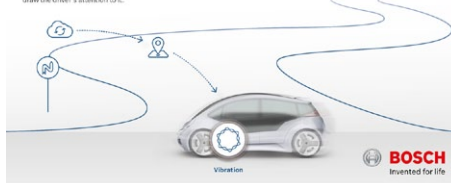

explains Stefan Seibert, president of Bosch's Gasoline Systems Division. Drivers can however override the gas pedal's feedback by applying more pressure.

Additional fuel-saving potential is available in conjunction with start-stop coasting, i.e. when the engine is stopped while still moving at speed in order to save fuel. Bosch estimates that the engine can be stopped in this way on 30 percent of all journeys. The gas pedal can be set to give an alert as soon as coasting mode makes sense. With advancing powertrain electrification, this technology offers further benefits. The pedal also opens up fuel-saving potential in hybrids, since it lets drivers know when the combustion engine is about to take over from the electric motor, so they can lighten the amount of pressure on the gas pedal.

In connection with collision warning systems, the gas pedal can issue a vibration signal, warning drivers not to kick the pedal any further. Type and force of the haptic feedback can be set by software parameters.





8:15

97%

# Apps Available at EBV!



Q TQ by EBV



Q EBV Products

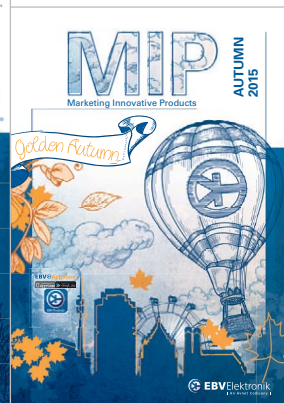

# Download Now!



Available on the iPad  
**App Store**



ANDROID APP ON  
**Google play**

For more information, please visit the **EBV AppStore** at [www.ebv.com/app](http://www.ebv.com/app).



Distribution is today. Tomorrow is EBV!

[www.ebv.com](http://www.ebv.com)

**EBV Elektronik**  
| An Avnet Company |

# Beagle Bone Green vs. Black: a Side by Side Comparison

By Lynnette Reese, Mouser Electronics

Open source hardware (OSHW) has created a new paradigm in embedded engineering. Science used to be freely shared, then everything became copyrighted, patented, or proprietary. OSHW is a new way to market microcontrollers, educate people, and share ideas, methods, and schematics freely. A new OSHW single board computer has arrived: the Beagle Bone Green (BBG), an off-shoot of the Beagle Bone Black (BBB). Several tables below include the basic facts necessary to quickly compare these two boards.



Figure 1: The Beagle Bone Green from Seeed Studio is in stock now at Mouser.com

Beaglebone Green is a well-planned update to Beaglebone Black, and has the same 32-bit Sitara™ ARM® Cortex®-A8 processor that runs up to 1GHz with 512MB RAM. BBB came out in 2013, so there's a good amount of community-shared software that works on both. BBG ships with Debian Linux, and costs about 20% less than the Black. (Both boards qualify as a bonafide Linux box.) Most changes from BBB to BBG are in peripherals.

BBG supports both capes and open-source, click-in "Grove" modules from Seeed Studio. BBG does not have HDMI, although since BBG also supports capes, a work-around is possible. The 5V power jack has been replaced by microUSB (µUSB) for BBG power, and there's an RTC with battery backup. For

	Beaglebone Black (BBB) - Rev C	Beaglebone Green (BBG)
Board Dimensions	3.4" (L) x 2.1" (W)	3.4" (L) x 2.1" (W) x .75" (H) (Height is with micro USB cable plugged in)
Board Weight	1.4 oz (39.68 g)	Same as BBB
Printed Circuit Board	6 layer PCB	Same as BBB
Processor	Texas Instruments Sitara AM3358BZC100 RISC	Same as BBB
Description of Processor	3D graphics processing, peripherals & industrial interfaces (see below). Supports high-level operating systems (OS) Linux® and Android™. Standby power draw: ~25mW, Deep Sleep: ~7mW	Same as BBB
Architecture	Sitara™ ARM® Cortex®-A8	Same as BBB
Speed	1 GHz Max	Same as BBB
Width, Instruction Set	32-bit	Same as BBB
Real Time Clock (RTC)	No	Yes, with battery backup
Watch Dog Timer	Yes, but must be initially activated by writing to /dev/watchdog. Reset/reboot default is 60 sec.	Same as BBB
Cache	32KB of L1 Instruction & 32KB of Data Cache	Same as BBB
RAM	512MB DDR3	Same as BBB
Storage	* BBB Rev.C: 4GB eMMC on-board flash storage *Micro SD card slot	*A single 256Mb x16 DDR3L 4Gb (512MB) memory device is used on-board in BBG *Micro SD card slot
EEPROM	4KB	Same as BBB
External Storage	Micro-SD-card & support for an external USB2.0 drive	Same as BBB
Video Support	HDMI	Via add-on cape as a workaround
Audio Support	Yes, via HDMI (stereo)	No; maybe via cape/USB audio card - untested.
Status Indication	1 - Power on LED 2 - Ethernet LEDs located on the RJ45 (Yellow for Link up if on, Green flashing for traffic) 4 - User-defined LEDs via setting GPIO pins	Same as BBB
JTAG	Built-in JTAG emulator via USB. See "Getting started with JTAG and CCS" <a href="http://beagleboard.org/static/Docs/ccs-jtag-simple.htm">http://beagleboard.org/static/Docs/ccs-jtag-simple.htm</a>	Built-in JTAG emulator via USB. See "Getting started with JTAG and CCS" Same address as on left. A place exists for an optional 20 pin CTI JTAG header
Serial Debug	Serial port is available via the J1 header, using the FTDI USB to Serial adaptor. (Only pins 1, 4 and 5 are connected on the board, so Vcc on pin 3 of the FTDI adaptor does not affect the Beaglebone.)	Serial debug is provided via UART0 on the processor via a single 1x6 pin header. In order to use the interface a USB to TTL adapter is required.
Module Compatibility	Capes	BBB compatible Capes and Grove modules by Seeed Studio ( <a href="http://www.mouser.com/seeed-studio-grove">www.mouser.com/seeed-studio-grove</a> )
Analog I/O	7 pins (AIN pins are rated 0 - 1.8V only)	Same as BBB
Digital I/O (aka GPIO)	65 pins (rated 0 - 3.3V only)	Same as BBB
PWM	8 total.	Same as BBB

Table 1:

	Beaglebone Black	Beaglebone Green
DC Power Supply (V <sub>IN</sub> )	*5V barrel jack *MiniUSB *5VDC via expansion header (5V @ 1A max)	*USB port on a PC *A power supply with a USB connector. *External Power@5 volts via P9 Expansion header VDD_5V pin (5V @ 1A max)
Ethernet cable	Cat5e/Cat6; not included.	Cat5e/Cat6; not included.
USB 2.0 type A/B-micro cable	Included, a 6-inch long A/B micro cable.	Included, a 6-inch long A/B micro cable.
SD Card	MicroSD card, not included.	MicroSD card, not included.
Powered USB Hub	Not included. Recommended to power any USB peripherals that would take current draw above 500mA, since a regular USB port has a maximum of 500 mA. (E.g., wired mouse, keyboard)	Same as BBB.

Table 3: Board Requirements



additional BBG power, there's also a 5V supply pin, or you can add a USB hub.

Although similar in layout, the BBB board is black, whereas BBG is green. The BBG kit from Seeed Studio includes board, QS manual, and a short  $\mu$ USB-B to standard-A cable. Much of what you need, including boot up and a complete manual, is stored on the board itself, which acts like a USB thumb drive when you plug it in to a PC.

The BBG has two 46-pin stackable expansion headers and two new Grove module headers; one for Grove I<sup>2</sup>C modules, and the other for UART Grove modules. Most Grove modules are I<sup>2</sup>C-based, and there is a Grove I<sup>2</sup>C hub for expansion.

Grove modules for BBG include an accelerometer, gyro, compass, LED, button, buzzer, light sensor, ADC, display, relay, servo motor, switch, temperature sensor, barometer, and even a heart rate monitor that clips onto your finger. Beagle Bones are a painless launch into embedded applications without soldering, and include a highly developed, flexible coding experience with many programming choices like C++, Python, Ruby, and others ([www.beaglebone.org/source](http://www.beaglebone.org/source)).

Communities for Beagle platforms provide resources for many code examples, shared projects and forums where BBB information can be applied to BBG (<http://beagleboard.org/green>). You can find more about open source hardware at [www.mouser.com/applications/open-source-hardware](http://www.mouser.com/applications/open-source-hardware)

Meet us at the exhibition Embedded World 2016 (February 23 – 25, Nuremberg, Germany), Stand 4A-101. Enter now our online competition for a chance to win one of the latest high end dev tools at [www.mouser.com/embeddedworld](http://www.mouser.com/embeddedworld)

	Beaglebone Black	Beaglebone Green
USB 2.0	HS USB 2.0 Client Port (Standard A) LS/FS/HS USB 2.0 Host Port (mini USB)	USB0: HS USB 2.0 Client Port (Standard A) USB1: LS/FS/HS USB 2.0 Host Port ( $\mu$ USB)
Ethernet	Yes, one 10/100 RJ45 port	Same as BBB
SD Card Slot	One $\mu$ SD that can be the primary boot source	Same as BBB
I <sup>2</sup> C	Yes	Yes
Two Wire Interface (TWI)	Yes	Yes
SPI	Yes	Yes
Serial Data (UART TTL)	UART0 access via 6 pin 3.3V TTL Header	Same as BBB and header is populated.
UART	Yes	Yes
Buttons (manual User Input)	1 - Board reset button. 1 - Power button for orderly shutdown. Power button will power up board if pressed again. 1 - Boot button; depress to boot from SD card.	Same as BBB
Headers	Power 5V, 3.3V, VDD_ADC(1.8V) 3.3V I/O on all signals, McASP0, SPI1, I2C, GPIO(69 max), LCD, GPMC, MMC1,MMC2, 7 AIN(1.8V MAX), 4 Timers, 4 Serial Ports, CAN0, EHRPWM(0,2), XDMA Interrupt, Power button, Expansion	Same as BBB
EEPROM	No	No
HDMI	Yes. A microHDMI cable adapter may be necessary. <a href="http://www.mouser.com/access/?pn=485-1358">http://www.mouser.com/access/?pn=485-1358</a>	Cape add-ons.
DVI	Cape add on ( <a href="http://www.mouser.com/beaglebonecapex">www.mouser.com/beaglebonecapex</a> ). Possible with HDMI/DVI adapter (545-P130-08N on mouser.com)	No
VGA	Cape add-on; or Micro HDMI to VGA adapter (545-P131-06N-MICRO on mouser.com)	Cape add-ons.
Touchscreen Display	LCD Touch Display	Same as BBB
Industrial Protocols	1588, EtherNet/IP, PROFIBUS, PROFINET, SERCOS	Same as BBB
CAN	Yes	Yes
CAN Bus	Yes, via Cape add on.	Same as BBB
Profibus	Yes, via Cape add on.	Same as BBB
LVDS	Yes, via Cape add on.	Same as BBB
Printer, 3D Printer	Yes, via Cape add on.	Same as BBB
Camera	Yes, via Cape add on.	Same as BBB
Geiger	Yes, via Cape add on.	Same as BBB

Table 2: Comparison of Peripherals/Utilities

	Beaglebone Black	Beaglebone Green
Boots from:	*eMMC on-board Boot - default, ships with pre-flashed image *SD Boot from SD card *Serial Boot - requires USB-to-serial cable *USB Boot	*eMMC on-board Boot - default, ships with pre-flashed image *SD Boot from SD card *Serial Boot - requires USB-to-serial cable *USB Boot
Operating System(s) for the Target	Linux, Neutrino, Integrity, Windows Embedded CE, VXWorks, Android, FreeBSD, and others.	Same as BBB
Integrated Development Environment (IDE)	Code Composer Studio, based on open source Eclipse IDE. <b>Free license</b> is enabled that supports working with Beaglebone onboard debug interfaces. As of Aug 2015, a subscription is NOT required for major upgrades. <a href="http://www.ti.com/tool/ccstudio-sitara">www.ti.com/tool/ccstudio-sitara</a>	Same as at left. Also: <a href="http://www.ti.com/tool/ccstudio-sitara">http://www.ti.com/tool/ccstudio-sitara</a> or see "Getting started with JTAG and CCS" in path: Docs/ccs-jtag-simple.htm located on your BBG.
Free Software Development Kits by TI	Yocto Project compatible LINUX EZSDK for Sitara and ANDROIDSDK-SITARA	Same as BBB
Supported Host-resident OS (System Console)	Linux, Windows	Same as BBB
Programming languages	C++, Python, Userspace Arduino, Starterware (by TI); on Cloud9 IDE: Bonescript, JavaScript, HTML, CSS, PHP, Java, Ruby & many more.	Same as BBB
Drivers	Automatically install regardless of Host system	Same as BBB
Boots from:	GNU/Linux Debian distribution from on-board flash	Same as BBB

Table 4: Comparison of Software and Development Tools

# Biometrics on the steering wheel: the ultimate life tracker

By Julien Happich

Judging from recent demonstrators and technology announcements, biometrics is high on the agenda of the connected car. Fingerprint sensors have already reached some level of consumer acceptance to secure their laptops and smartphones. According to market research firm IHS Inc., unit shipments of fingerprint sensors have grown from 316 million in 2014 to 499 million in 2015 and will continue to increase each year to peak at 1.6 billion in 2020.

Cars which are much more costly than smartphones and becoming increasingly connected, are the logical next step, it seems. A number of standalone fingerprint-based car starters and car locks have been around for a few years now on the automobile after-market. Design cycles in the automotive industry are notoriously longer than in the smartphone industry, but solution vendors are looking for a strategic expansion into this market (after having successfully moved from the government and banking high-security access domain to the consumer domain).

Early January, global provider of silicon fingerprint sensors Fingerprint Cards (FPC) publicly stated that its solutions were under evaluation by leading global car makers and other automotive integrators, expecting its touch fingerprint sensor chip FPC1025 to be seen in a number of demos and public demonstrations for automotive applications during 2016.

Joined over the phone by *EETimes Europe*, FPC's CEO Jörgen Lantto is confident about the penetration of fingerprint scanners in cars. "Today for the smartphone industry, we ship about one million units per working day. That means our solution is used several billion times per day and is well proven. Although it's too early to tell when the automotive industry will represent a mass market for fingerprint scanners, our customers and OEM partners have already given us their predictions and our impression is that there is a serious intent to move forward with this technology".

"The pace at which it will happen will depend on consumer experience. If it's great, this could accelerate acceptance and market penetration" he concluded.

Boasting flexibility and inconspicuous design, FlexEnable and ISORG revealed a large area fingerprint and vein sensor (86x86mm) designed on plastic, a solution that could wrap around a steering wheel, they say. The sensor film is only 0.3mm thick and can operate in visible and near infra-red up to wavelengths of 900nm, measuring not only the fingerprint, but also the configuration of veins in the fingers for additional security versus that of a surface fingerprint alone. Designed at a 84µm pitch, the 1024x1024 pixels sensor features a 302dpi resolution versus the FPC1025's 508dpi specification, though it could scan several fingers at once for increased security and does not require optics.

The companies did not specify if they had built demonstrators specifically aimed at seducing automotive OEMs, but FlexEnable already develops conformable cockpit displays, which in principle, could also integrate the palm-sized fingerprint sensing solution.

Touch-sensing company Synaptics is also keen to enter the automotive market with its capacitive-based Natural ID fingerprint touch area technology. While the company is massively present in the smartphone market and has just made public its cooperation with Intel and Lenovo to develop a secure enterprise-level fingerprint authentication for the next generation Lenovo ThinkPad notebooks, on the automotive front, it has built a steering wheel demonstrator. At CES 2016, it showcased an 8x8mm Natural ID fingerprint sensor integrated on the directional pad (D-Pad) of a steering wheel. On top of the usual user interface navigation capabilities offered by the D-Pad, the sensing area gave the user access to in-car payment and customized car settings.

Anti-theft and comfort are the most trivial features car makers will sell to consumers, and in principle, you could well implement fingerprint-based security for a number of anonymous drivers without ID authentication, say by enrolling user 1, then user 2 etc... and never refer to a specific user identity.

But that's not what car makers consider the key role of a biometrics-enabled user interface, it seems.

And being able to formally identify who is in the driver's seat has more implications than just allowing in-car payment in a parking lot.

Synaptics' Senior Vice President and General Manager of the Human Interface Systems Division (HISD), Huibert Verhoeven admits that with self-driving cars coming next, car makers' legal teams are working behind the scene to figure out who is in charge.

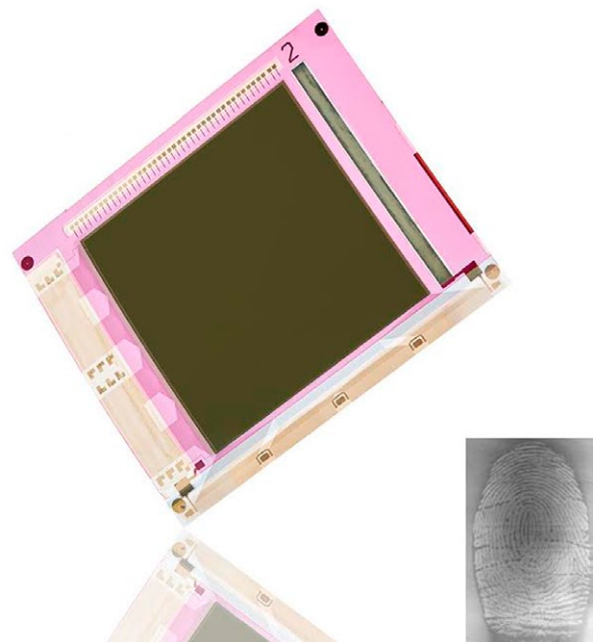

Flexenable and ISORG's joint flexible fingerprint sensor development.





Synaptics' 8x8mm Natural ID fingerprint sensor integrated on the directional pad (D-Pad) of a steering wheel.

"For liability issues, you want to know for sure who is in the driver's seat. Legal teams are worried about a four-year old driving to his grandma at the touch of a button" he explained.

In fact, more than just a key to more services, formal identification could be a requisite to operate any semi-autonomous or self-driving car.

Eventually, fingerprint authentication across multiple devices could make them interact in unexpected ways for the consumer. Patent WO 2014178934 A1 filed in 2014 by Continental Automotive Systems is looking at making sure that once a driver has been authenticated through a biometric identifier, the same biometric identifier recognised on his/her smartphone (providing the car and the cell phone communicate) would immediately disable the wireless communications to prevent driving while on the phone. The biometric identifiers listed include fingerprints but also face recognition from an inward looking cockpit camera.

Iris recognition is another technology that could surface into car cockpits. At this year's CES, EyeLock demonstrated a proof of concept to validate a driver and authorize engine start (the frills being personalized driver settings).

Other biometrics are being evaluated, which could enter the cockpit and make insurance companies more confident about allowing a car to be driven, sometimes relating to the driver's health condition.

Texas instrument has come up with a reference design for a concept demonstration of how a driver's pulse rate, respiration rate, and ECG based heart rate can be obtained from a vehicle steering wheel. The company's AFE4400 and AFE4300 biometric analog front-ends (AFE) enable the acquisition of all three parameters via simple hand contacts on the steering wheel. The reference design includes a full BLE connectivity design for easy interface to smartphones and tablets.

Inferring the driver's health condition from such biometrics could help the car make such decisions as reducing speed, increasing the distance



TI's TIDA-00292 biometric steering wheel reference design.

between vehicles, or changing route altogether to alleviate road-rage.

Leveraging and connecting wearable fitness and health trackers to a vehicle's infotainment system, Ford is looking at exploiting a driver's health information beyond what a car's sensor network could collect. Last December, Ford Motor Co. teamed up with Henry Ford Health System to sponsor a tech design challenge for employees to "develop concepts, such as smartphone apps, wearable devices or in-vehicle systems that could extend healthcare to the confines of a car".

Resulting apps could expand the boundaries of patient monitoring, turning the car into a health-check capsule, not only for general health monitoring but also to issue warnings or to simplify health-related administrative tasks (medical test ordering, records access, appointment check-ins, prescription pick-ups). With more sensors being integrated in the car (including why not sweat-based alcohol and drugs tests), more biometric data could be collected and analysed to establish a driver's capacity to sit responsibly behind the wheel.

Eventually, with ID authentication and personalized health checks carried out in the car, will insurance companies decide when you ought to drive or not and what sort of driving is safe enough for the would-be driver?

Is the individual car - once the freedom engine of the American dream - on the cusp of turning into the most scrutinized space on earth, a sort of high-security cell keeping the driver on probation?

Found guilty or suspicious of anything while in the cockpit?

Boosted by their artificial intelligence, tomorrow's data mining algorithms could well decide to lock you in and drive you to the nearest police station, be it for your own good or for the safety of others.

# MIT neural network IC aims at mobiles

By Peter Clarke

**M**IT researchers have designed a chip to implement neural networks and claim it is 10 times as efficient as a mobile GPU. This could be used to allow mobile devices to run artificial-intelligence algorithms locally, rather than uploading data to the Internet for processing. MIT researchers have presented a chip designed specifically to implement neural networks at the International Solid State Circuits Conference in San Francisco.

“Deep learning is useful for many applications, such as object recognition, speech, face detection,” said Vivienne Sze, a professor in MIT’s Department of Electrical Engineering and Computer Science whose group developed the chip.

The chip is called Eyeriss and the idea is that training up the network for specific functions could be done “in the cloud” and then the training configuration – the weighting of each node in the network could be exported to the mobile device.

The chip has 168 cores each with its own memory with the idea to minimize the frequency with which cores need to exchange data with distant memory banks. When such exchanges are off-chip in particular it consumes much time and energy.



The chip has a circuit that compresses data before sending it to individual cores and each core is also able to communicate directly with its immediate neighbors, so that if they need to share data, they don’t have to route it through main memory.

The final key to the chip’s efficiency is a circuit that allocates tasks across cores. In its local memory, a core needs to store

not only the data manipulated by the nodes it’s simulating but also data describing the nodes themselves. The allocation circuit can be reconfigured for different types of networks and applied across the network at the start of running the application.

As part of the ISSCC presentation the MIT researchers used Eyeriss to implement a neural network that performs image-recognition.

“In addition to hardware considerations, the MIT paper also carefully considers how to make the embedded core useful to application developers by supporting industry-standard [network architectures] AlexNet and Caffe,” said Mike Polley, a senior vice president at Samsung’s Mobile Processor Innovations Lab. The MIT researchers’ work was funded in part by DARPA.

# Neural network built in plastic

By Peter Clarke

**A** team of scientists from Russia and Italy have created a neural network made from plastic memristors. Kurchatov Institute, MIPT, the University of Parma, Moscow State University, and St. Petersburg State University have demonstrated that it is possible to create simple polyaniline-based neural networks that are able to learn and perform logical operations. The work is reported in *Organic Electronics*.

A memristor is an electrical element with a variable resistance that depends on the charge passing through it and which displays memory. It has long-been noted that a memristor is similar to a biological synapse – a connection between two neurons in the brain that is able to modify the efficiency of signal transmission between neurons under the influence of the transmission itself.

To date studies of synapse-like behavior have been done in silicon-based memristor-type devices. Using a polyaniline solu-

tion, a glass substrate, and chromium electrodes, team created a polymeric memristor at a scale of about 1 millimeter and multiple memristors were then connected in a single neuromorphic network. Under supervised learning the memristive network is capable of performing NAND or NOR logical operations.

This perceptron node is of macroscopic dimensions and with a characteristic reaction time of tenths or hundredths of a second, but the researchers state that this should scale with dimensions and the neural network is made using inexpensive materials. In addition, polyaniline can be used in attempts to make a three-dimensional structure by placing the memristors on top of one another in a multi-tiered structure.

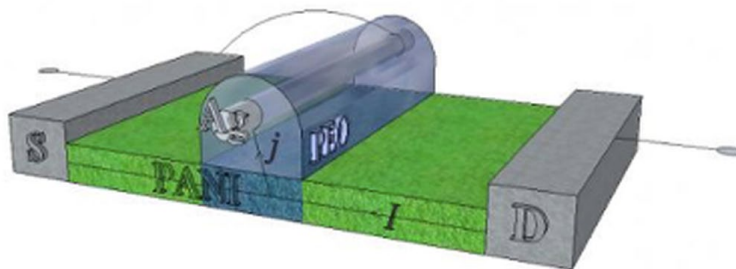

Typical applications for neuromorphic computers include machine vision, hearing, and emulating other sensory organs, and also intelligent control systems for various devices, including autonomous robots and drones.



# High Accuracy, High Speed Position Sensors!

## MagAlpha Series

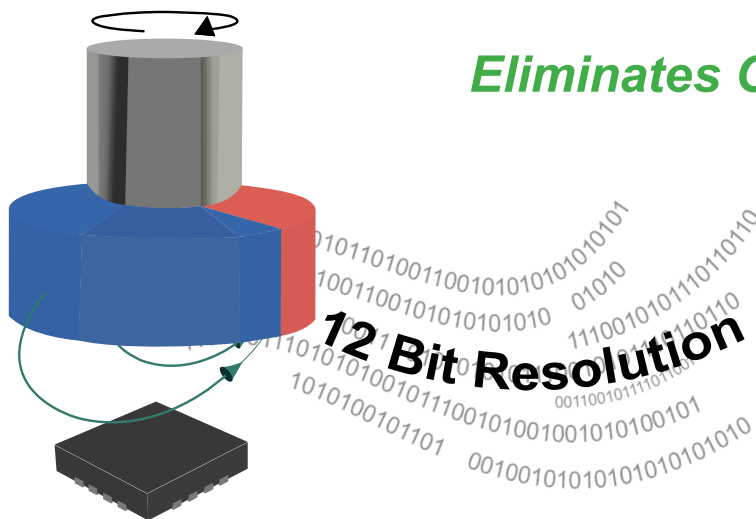

### MagAlpha MA300 Features

- UVW Signals for Block Commutation
- 12-Bit Resolution Absolute Angle Encoder
- 500kHz Refresh Rate
- Ultra-Low Latency: 3 $\mu$ s
- Serial Interface for Data Readout and Settings
- 10-Bit Incremental Output (A, B, Z)
- Built-In Linearization for Side-Shaft Mounting
- 7.5mA Supply Current

*Flexible  
Mounting*

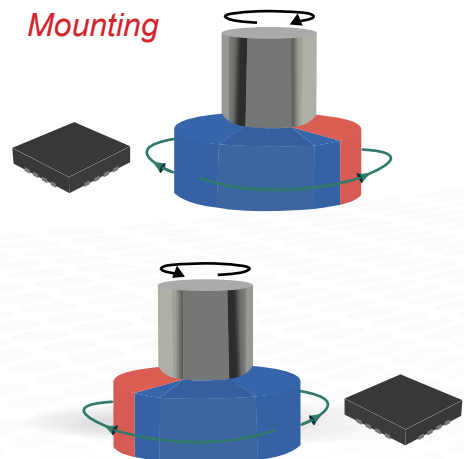

# Google's deep learning comes to Movidius

By Junko Yoshida

**M**ovidius, an ultra-low-power computer vision-processor startup best known for its partnership with Google on Project Tango, has extended its relationship with Google. This time, the collaboration is focused on neural network technology, with plans to accelerate the adoption of deep learning in mobile devices.

In an interview with EE Times, Remi El-Ouazzane, CEO, Movidius, called the agreement “a new chapter” in the partnership.

In Project Tango, Google used a Movidius chip in a platform that uses computer vision for positioning and motion tracking. The project's mission was to allow app developers to create user experience that works on indoor navigation, 3D mapping, physical space measurement, augmented reality and recognition of known environments.

The new agreement with Google is all about machine learning. It's intended to bring super intelligent models—extracted from deep learning at Google's data centers – over to mobile and wearable devices.

El-Ouazzane said Google will purchase Movidius computer vision SoCs and license the entire Movidius software development environment, including tools and libraries.

Google will deploy its advanced neural computation engine on a Movidius computer vision platform.

Movidius' vision processor will then “detect, identify, classify and recognize objects, and generate highly accurate data, even when objects are in occlusion,” El-Ouazzane explained. “All of this is done locally without Internet connection,” he added.

The public endorsement from Google will boost the startup, said Jeff Bier, a founder of the Embedded Vision Alliance. The announcement is also “interesting,” he added, because it shows “Google has a serious interest in [the use of deep learning for] mobile and embedded devices.” It demonstrates that Google's commercial interest in artificial neural networks isn't limited to their use in data centers.

Different teams within Google, including its machine intelligence group (Seattle), are involved in this agreement with Movidius. Google will be developing commercial applications for deep learning. Movidius is “likely to get more input from Google, and get opportunities – over time – to optimize its SoC for Google's evolving software,” Bier speculated.

Movidius' agreement with Google is unique. “Not everyone has access to Google's well-trained neural networks,” said El-Ouazzane, let alone the opportunity to collaborate on computer vision with the world's most prominent developer of machine intelligence.

Asked if the work with Google involves the development of embedded vision chips for autonomous cars (i.e. Google Cars), Movidius CEO El-Ouazzane said, “Google intends to launch a series of new products [based on the technology]. I can't speak on their behalf. But the underlying technology – high quality, ultra-low power for embedded vision computing – is very similar” whether applied to cars or mobile devices.

For now, however, Movidius' priority is getting its chip into mobile and wearable devices. El-Ouazzane said, “Our [embedded vision SoCs] are to the IoT space, as Mobileye' chips are to the automotive market.” Mobileye today has the lion's share of the vision chip market for Advanced Driver's Assistance Systems.

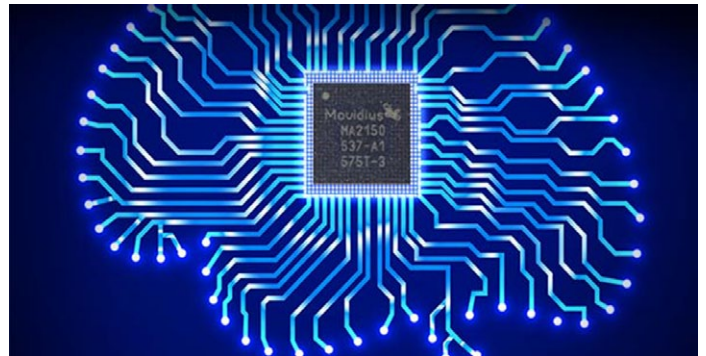

Fig. 1: Movidius' embedded vision SoC.

The search giant is hungry for technology to “recognize human speech, objects, images, emotion on people's faces, or even fraud detection,” explained Bier. “Google has a commercial interest in understanding context better, when people are searching for certain things.”

However, both physical objects and human emotions are ambiguous, and they come with infinite variability, Bier said.

They pose hard problems for computers that tend to seek solutions “in formulaic ways.” “These are the tasks we don't know how to write instructions for. They have to be learned by examples,” as Blaise Agüera y Arcas, head of Google's machine intelligence group in Seattle, said in Movidius' promotional video.

In recent years, though, “machine learning is cracking the problem,” said Bier.

Before the emergence of Convolutional Neural Networks (CNN) in computer vision, algorithm designers had to design many decisions through many layers and steps with vision algorithms. Such decisions include the type of classifier used for object detection and methods to build an aggregation of features.

In other words, as Bier summed up: “Traditional computer vision took a very procedural approach in detecting objects.” With deep learning, however, designers “don't have to tell computers where to look. Deep learning will make decisions for them.”

With all the learning and training carried out in the artificial neural network, “Computers are now gaining intuition,” said Bier.

Obviously, Google wants to expand this technology beyond the data center, by bringing it to mobile devices used in the real world.

## Keeping decisions local

In theory, Google's Android device, equipped with an embedded vision-processing chip, would know more about its user and predict better the user's needs. It could intuit and provide what the user wants, even when the device is offline.

Picture, for example, a swarm of mobile, wearable devices or even drones equipped with Movidius' embedded vision SoC, said El-Ouazzane. They can autonomously classify and recognize objects in an unsupervised manner. And they don't have to go back to the cloud. When connected, the devices can send less detailed metadata back to the trained network. The network in return sends back updated layers and weights learned



in the artificial neural network.

“Deep learning isn’t a science project” for Google, said Bier. “It gives Google clear, commercial advantage for its business.” The alliance with Movidius won’t preclude Google from working with other embedded vision SoC vendors. Surprisingly, though, very few embedded vision SoCs are on the market today, said Bier, although there are silicon IPs now available from companies like Ceva, Cadence and Synopsys.

Chip vendors are using everything from CPU and GPU to FPGA and DSP to enable CNN on vision SoCs. But when it comes to chips optimized for embedded devices like wearables, “You need a chip that costs less and runs at very low power,” Bier said.

Qualcomm is offering embedded vision on its “Zeroth platform,” a cognitive-capable platform. Some system vendors are using Xilinx Zynq FPGA for it. Cognivue, now a part of NXP Semiconductors, claims a chip designed for parallel processing of sophisticated Deep Learning (CNN) classifiers. But NXP’s focus is solely set on automotive, a growing market dominated by Mobileye.

### A swerve towards CNNs

Movidius CEO stressed, “It’s one thing to talk about theories, but it’s another to deploy CNN on a commercially available chip on milliwatts of power.”

EI-Ouazzane acknowledged that when the company first developed its computer vision chip, “We weren’t necessarily thinking about CNN.” But in the last few years, “we’ve seen the industry’s accelerated interest in the use of CNN in the cloud.” It turns out that Movidius’ chip, serendipitously, is well designed for artificial intelligence neural networks.

Google picked Movidius because the startup’s latest chip, MA2450, is the only chip commercially available that can do machine learning on the device. MA2450 is a member of Movidius’ Myriad 2 family of vision processing unit SoCs.

Myriad 2 provides “exceptionally high sustainable on-chip data and instruction bandwidth to support the twelve processors, 2 RISC processors and high-performance video hardware accelerators,” according to the company.

### A close SHAVE

In particular, it contains a proprietary processor called SHAVE (Streaming Hybrid Architecture Vector Engine). SHAVE contains wide and deep register-files coupled with a Variable-Length Long Instruction-Word (VLLIW) controlling multiple functional units including extensive SIMD capability for high parallelism and throughput at both functional unit and processor levels.

The SHAVE processor is “a hybrid stream processor architecture combining the best features of GPUs, DSPs and RISC with both 8/16/32 bit integer and 16/32 bit floating point arithmetic as well as unique features such as hardware support for sparse data structures,” explained Movidius.

MA2450 is an improvement on the company’s MA2100, according to EI-Ouazzane. The MA2450 uses TSMC’s 28nm HPC process, while MA2100 uses TSMC 28nm HPM. Computer vision power in MA2450 is one-fifth of that of MA2100 and the power of MA2450’s SHAVE processors has been reduced by 35 percent. MA2450’s memory increased to 4GDRAMigabit

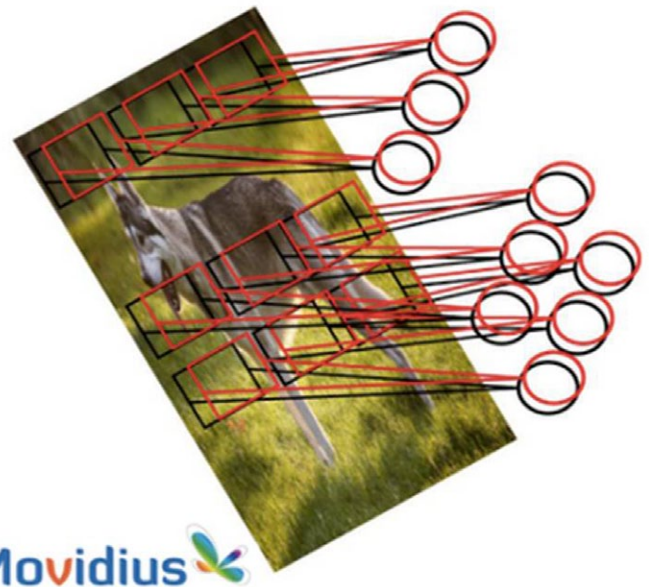

Fig. 2: The segments of the image are fed through nodes of the convolutional network. They start to differentiate not at the pixel level, but at the feature level (ie. Paws, whisker, etc). CNN is far better at classification than older approaches where the programmer must explicitly code a set of rules. (Source: Movidius)

DRAM from MA2100’s 1Gbit. The 2 32-bit RISC processors inside MA2450 run at 600MHz, compared to 500Mhz in the older SoC.

Meanwhile, the industry’s interest in deep-learning-based computer vision is rapidly growing. Bier said the Embedded Vision Alliance is offering a tutorial on CNN and a hands-on introduction to the popular open source Caffe framework on February 22nd with primary Caffe developers from the Berkeley Vision and Learning Center at U.C. Berkeley.

### A special microarchitecture optimized for power efficiency

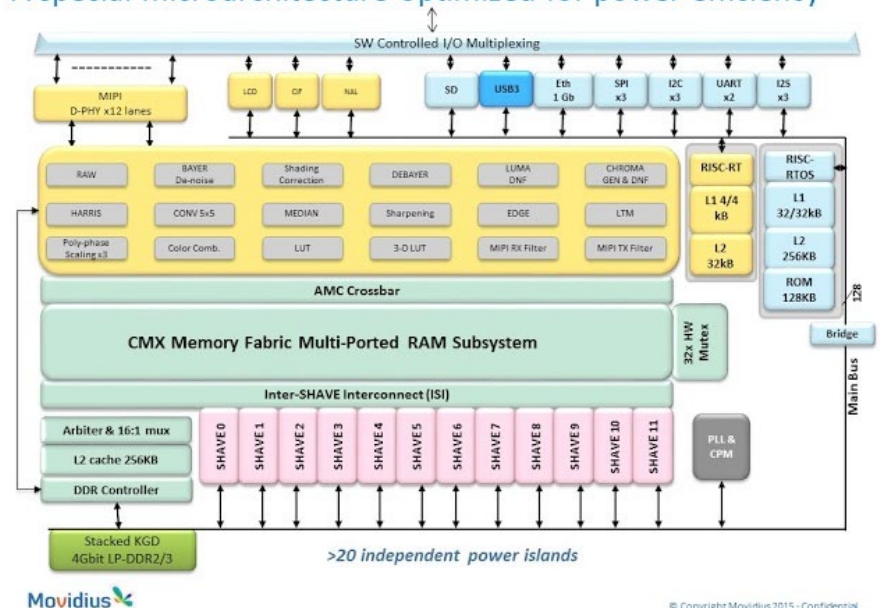

Fig. 3: Myriad 2’s special micro-architecture (Source: Movidius).

## Nissan pumps £26.5m into UK Li-ion battery plant

By Paul Buckley

**N**issan has given a vote of confidence in European manufacturing by awarding production of future generation electric vehicle (EV) batteries to the company's manufacturing facility in Sunderland, UK.

The £26.5 million investment will help safeguard 300 highly-skilled jobs in manufacturing, maintenance and engineering at Nissan's advanced lithium-ion battery plant in Sunderland, the largest of its type in Europe.

The Sunderland facility is one of three Nissan battery production sites globally and will provide battery modules for the all-electric Nissan LEAF and e-NV200 electric van, which is manufactured at Nissan's facility in Barcelona, Spain.

Already the global leaders in electric vehicles with more than 200,000 Nissan LEAF models on the road worldwide covering a total of two billion electric miles. In 2015 Nissan sold 43,651 LEAFs worldwide with 15,630 of that number being sold in Europe.

Paul Willcox, Chairman, Nissan Europe, said: "The announcement reflects Nissan's intention to remain EV leaders for many years to come, with our European operations at the heart of our future innovations."

Since EV production began in Sunderland in 2013 bolstered by a £420m investment, the battery plant and Nissan LEAF production have supported more than 2 000 jobs both at Nissan

and within the supply chain.

The Nissan Leaf was the first electric car to be mass-produced in the UK - about 60,000 batteries are produced at the plant each year.

"Nissan has achieved second-to-none quality levels since launching battery manufacturing in Sunderland, and securing this critical future production is a testament to our success. This news coincides with the launch of the 250km range Nissan LEAF. Now in its third generation, the LEAF continues to go from strength to strength as we realize our electric motoring vision," said Willcox.

The announcement comes at the beginning of a landmark year in which Nissan will celebrate the 30th anniversary of its Sunderland factory (now the largest plant in the history of the UK car industry) and the 10th anniversary of its St Petersburg Plant in Russia. The St Petersburg facility celebrated production of its 200,000th vehicle in 2015, making it the fastest growing plant in Russia.

The Nissan investment is a further sign of the resurgence of the UK's motor industry. The UK's Society of Motor Manufacturers and Traders released this week figures that show 1.59m vehicles in 2015 were built in UK factories, the highest number since 2005.

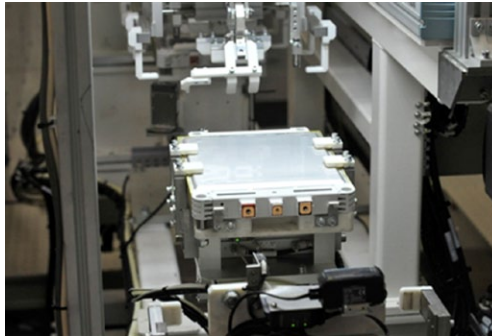

## BMW launches energy storage company

By Christoph Hammerschmidt

**E**lectromobility is increasingly becoming a component in a multidisciplinary energy interaction - with the batteries being the pivotal point in the system. The latest move in this game: Carmaker BMW has launched a joint venture with heating systems vendor Viessmann Group.

Under the name Digital Energy Solutions, the BMW-Viessmann joint venture will offer energy management solutions and related consulting services. According to BMW's press release, the strategy of the new company will pursue an overarching approach that spans disciplines like electromobility, electric power, air conditioning and heating. For the time being, the offer is directed to small and medium-sized companies in Germany and Austria.

BMW contributes its expertise in electromobility as well as its charging infrastructure access service ChargeNow - according to the carmaker, ChargeNow is the largest service of its kind in the world. In addition - and this is actually the more interesting part of the equation - the new company plans to establish a business field that integrates high-voltage batteries into smart, stationary energy storage systems. The batteries for these systems will originate from used electric vehicles. To a certain

extent, the company will also use new batteries. The system will be controlled by a purpose-built software called Smart Energy Backbone, developed by BMW. This software has been created on the basis of BMW's existing in-house energy management deployed in the company's global manufacturing network.

The decision to launch the new business is based on the consideration that with a globally increasing trend towards renewable energies, the demand for energy buffer and storage systems will rise, and electromobility will play an increasing role in this scheme. Another motivation is the endeavour to reduce the overall CO2 emissions per vehicle produced.

BMW is not the only vendor of electric vehicles to enter the energy storage business. Nissan and Daimler have established similar business branches independent of each other. According to a Daimler spokesperson, the business model for such storage systems is at least in part based on the fact that after the vehicles have reached their lifecycle, the batteries typically still have 80 percent or more of their capacity. Thus, the second use of these batteries seems an obvious application.





# AR browser unveils real world objects' digital life

By Julien Happich

**D**uring a live streaming conference held in Boston last January, PTC's president and CEO Jim Heppelmann shared his vision of Augmented Reality for the Internet of Things, two hot topics merged into one to englobe every possible aspects of life, from consumer to medical or industrial applications.

Over the last couple of years, the software service provider has made a number of strategic acquisitions to position itself at the forefront of both augmented reality and IoT. Last year, it acquired Vuforia and its augmented reality (AR) technology platform, and in 2014, PTC was acquiring ThingWorx and Axeda, both companies bringing key IoT connectivity and data management solutions.

Heppelmann started with a simple demonstration, showing a dull empty automotive dashboard, and suddenly bringing it to life with different sets of digital dials by simply looking at it through a tablet's video screen.

"In the future, with AR goggles, you could bring your personalized dials and dashboard interface in any car you buy" he said, inviting the audience to take a fresh look at things.

"Even before AR glasses become commonplace, the explosive adoption of smartphones and tablets is already taking AR to the mainstream", he noted, "and we need applications to bring value, to augment the analogue world with digital content". Consumers are mostly exposed to AR through companies' branding or advertising efforts, but augmented reality will revolutionize the world when we apply it to the enterprise, the CEO said.

Heppelmann showcased some interesting examples, such as that of sports motorcycles manufacturer KTM already using AR to speed up service and repairs in the workshop.

During a live demonstration, an untrained technician equipped with a tablet looked at a 690 Duke motorbike for which some faults had been reported by a customer. Using a dedicated maintenance dashboard, the technician was able to run a quick diagnostic indicating which parts had to be checked.

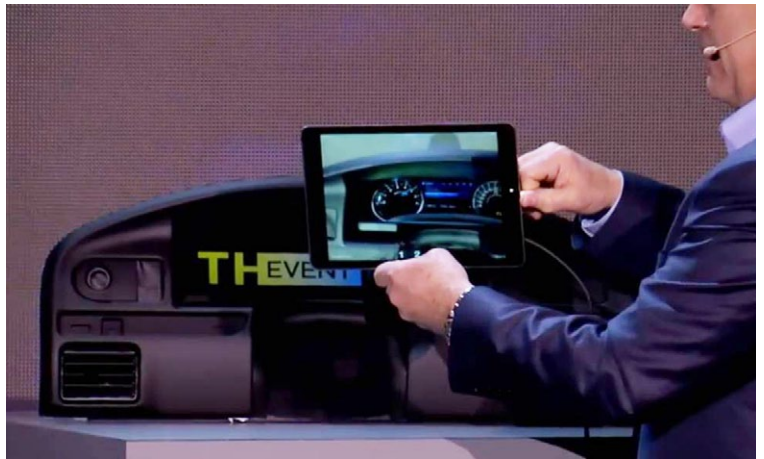

Turning a dumb surface into an exciting interface with AR.

Then, pointing the camera at the real bike, the AR application highlighted the faulty parts in 3D, pointing out their location on the bike while providing guidance for their disassembly and repair. Such an application not only helps technicians make the repair, but it ensures a more consistent service across the enterprise.

Machinery maker Caterpillar is another company already making use of AR to help field technicians carry out maintenance and repair. In fact, AR could make any machine servicing more proactive, you could even get real time feedback from objects or from the products being serviced.

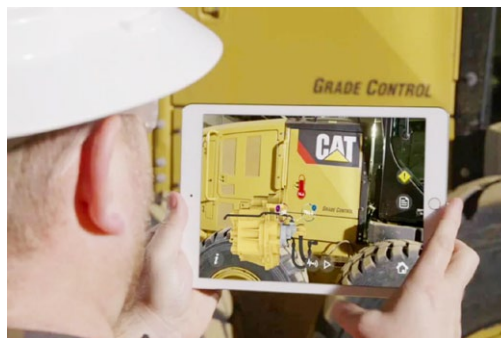

A caterpillar field technician looking at a machine's status on predictive maintenance.



Augmented reality highlights the parts that will need servicing and how to access them.



The VuMarks designed on the KTM motorbike triggers the AR browser.



Then augmented reality takes over to guide the repair technician step by step.

Combined with predictive data analysis, you could notify the customer that maintenance is required and with such guidance, the end-user could perform the maintenance task himself rather than having to wait for a technician to be dispatched.

"Who loves to read user manuals? Who needs them?" asked Jay Wright, Vuforia's Senior VP and General Manager, "In the future, no-one!" he concluded, presenting the future of personal contextual assistants, moving from today's 2D help screens to 3D augmented reality.

Wright described the three steps in which Vuforia, boasting over 25,000 commercial applications, more than 200K registered developers and over 230 million app downloads, brings AR to life.

“You’ve got the Vuforia engine which is like a digital eye that identifies things in the camera’s field of view and tell the app what it sees and creates the digital overlap of AR images.”

“As a developer, in order to create AR content, you must first choose a target that triggers the AR app. Then you must author the AR content, either with PTC or third party CAD tools and then you must stitch these things together.”

But for a smartphone, tablet or smart glass to identify and launch the relevant AR content, it needs some cues. Today, this is often implemented via a QRcode that the user must scan in order to be directed to the right app.

“Who wants a QRcode in their design?” asked Wright, pointing the tag as aesthetically unpleasing. Instead, the general manager unveiled the VuMark, an AR tag format able to sport any shape with graphics in its centre, only wrapped by a subtle coded contour itself surrounded by a customisable border.

“The VuMark lets users know where to look”, he explained, revealing that Vuforia’s engine was now Android, iOS and Windows 10 compatible.

In fact, the VuMark is already being used extensively by Lego to bring digital interactivity to its line of Nexo Knights toys, as Wright illustrated with promotional video clips from the toy manufacturer.

These technicalities served as an introduction to the big announcement coming next.

“AR has an enormous potential to overlay digital content over real objects, however, it comes with its own challenges” pointed out Mike Campbell, PTC’s Vice President.

“Imagine a world with 50 billion connected things, and imagine the millions of Apps necessary to interact with these objects”.

“We’re already beginning to see an explosion of purpose built Apps for connected products. Think of a refinery with tens of thousands of connected pumps and valves and then all the possible service, maintenance and control Apps that could be developed. Or imagine a factory with hundreds of different machines, each one of them with specific data valuable to different people”.

“In a world with so many smart connected thing, how are people going to know what things they can interact with and what App they need to access the data? How will they keep all these Apps up to date?”

“The answer is definitely not an App for everything”

Campbell emphasized, before announcing Project ThingX, an expansion of PTC’s IoT platform that according to him, is set to revolutionize the way Apps are delivered.

To be delivered by this summer, ThingX (short for Thing Experiences) will consists of three major blocks, namely Thing-Browser, ThingServer and ThingBuilder.

Similar to a web browser but for AR, ThingBrowser will be a unique App for people to interact with objects, simply looking at their surroundings with a tablet or smart glasses to identify which objects they can interact with (based on the VuMarks entering the field of view of the camera) and only bringing up the data relevant to them (maintenance instructions or marketing info for example).

ThingServer will manage the different experiences that can be served for a given object, dynamically loaded the different content options available depending on the person’s access rights (being an accredited technician or from the general public).

Then ThingBuilder will consist of an easy to use AR content creation environment, with a library of drag and drop CAD



Wright presenting the VuMarks already adopted by Lego’s Nexo Knight AR-enhanced toys.



Viewing the Lego through a tablet will trigger video content or additional character attributes.

elements that can be decorated with the information to put forward, or even data streaming from the things themselves.

Campbell ran through a short preview of ThingBuilder, taking as an example a smart server from Schneider Electric for which he quickly created interactive AR data feeds. He then published the new content to ThingServer for it to go live.

Now, it is not clear yet how the company will encourage today’s smartphone and tablet manufacturers to implement ThingBrowser and how it plans to raise consumers’ awareness beyond the enterprise world to reach defacto AR browser status. At the time of writing, the company was not able to comment if it would release ThingBrowser open source for developers to disseminate.



Demonstrating ThingBuilder’s user interface to create AR content intuitively.



Once uploaded, the AR content shows up when looked through a device’s camera.



# Micron 3-D NAND back to Moore

By R. Colin Johnson

**F**lash memory is back on the Moore’s Law scaling curve, according to Micron Technology Inc. (Boise, Idaho) thanks to its move into three-dimensional structures.

“3D gets NAND back on a regular scaling curve,” Kevin Kilbuck, Micron’s director of NAND Strategic Planning told EE Times. “Our first generation is 32 layers in the vertical direction while relaxing the x-y design rules back several generations.”

Prior to going 3D, Micron could only shrink each new generation in its x-y dimensions, but they hit the wall at 20-nanometers, only able to shrink in one direction—either x or y—at the 16-nanometer node. But by going 3D, Micron has been able to keep increasing chip capacity per package while relaxing the x-y scaling rules. Relaxing the x-y design rules improves the performance and reliability compared with sub-20nm planar NAND.

“As you approach the x-y scaling limit, you start running out of electrons and get a lot more interference,” Kilbuck told us. “Going 3D solved that problem for us, while still keeping the packages in the 1.0-to-1.4 millimeter range with the same pinout.”

In its fabs in Singapore and Lehi, Utah (half-owned by Intel) Micron’s first generation 3D NAND chips will be 32- and 48-gigabytes. With up to 16 layers in a single package super high density solid-state drives (SSDs) can be made for servers and data centers. For the future, Micron plans 2-terabyte 3D NAND packages, allowing an SSD using 16 of them to pack up to 32-terabytes.

“Our solution is the first 3D NAND technology built on a floating gate cell,” Kilbuck told EE Times. “It also has an architecture enabling industry-leading monolithic MLC and TLC die. Unlike competitive solutions, our first-generation 3D NAND is architected to achieve better cost efficiencies than planar NAND.

For consumer and mobile markets, lower density and much less expensive 3D NAND packages are also envisioned.

### 3D XPoint

Micron also has its 3D XPoint (pronounced cross-point) chips coming online in 2016. The 3D XPoint was developed with Intel

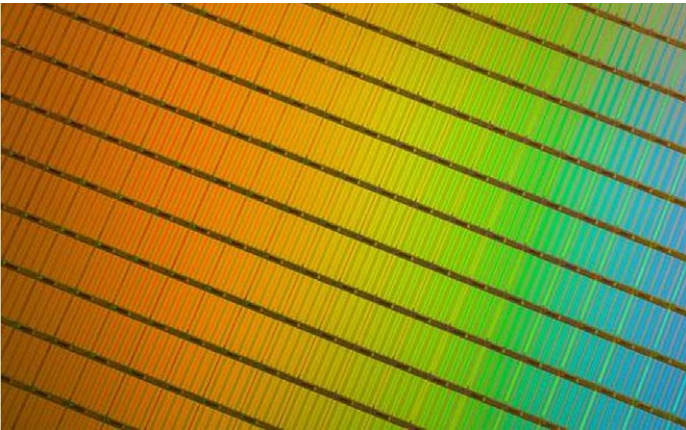

3D NAND wafer close-up reveals Micron and Intel unveil new 3D NAND technology with three times higher capacity than other NAND dies in production. (Source: Micron, used with permission)

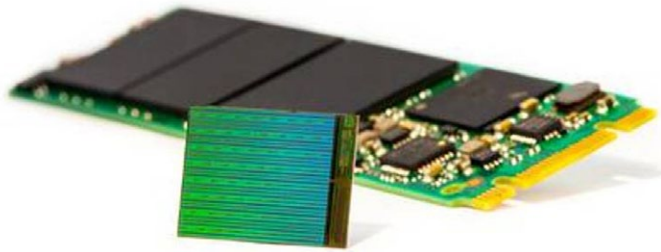

Micron’s 3-D NAND die is small enough to boost solid-state SSDs the size of gum sticks to 3.5 terabytes. (Source: Micron)

to realize a dream that IEEE Fellow Leon Chua, Hewlett Packard, Hynix and innumerable startups have been trying to realize for a decade—a high-density transistor-less memory cell. The idea is to put a material that increases its resistance whenever current is put through it in one direction, and reduces its resistance when current flows the opposite direction. Many such materials—called memristors by their inventor Chua—have been successfully tested in the lab, from exotics to plain-old silicon dioxide, but no one has been able to perfect the read/write process for mass production—until now.

Micron, with the help of Intel, promised to be sampling to major customers its ultra-high-density 3D XPoint chips in 2016, each layer of which will consist of a cross-bar array of word- and bit-lines with their proprietary secret-sauce material in-between. Sometimes called resistive RAMs (Re-RAMs or just RRAMs) Micron/Intel claim to have finally worked out the kinks plus be able to stack XPoint layers atop each other for 3-D calibre densities.

So far they are keeping their secret-sauce resistance changing material a secret, but their pitch is that in the end 3D XPoint will be ultra-dense, close to DRAM in performance, but closer to flash in cost. High performance solid-state drives will be the first beneficiaries, according to Kilbuck, filling the gap between “storage and memory” for data centers. Later consumer versions will be introduced circa 2018 after mass production has reduced their price closer to flash based SSDs.

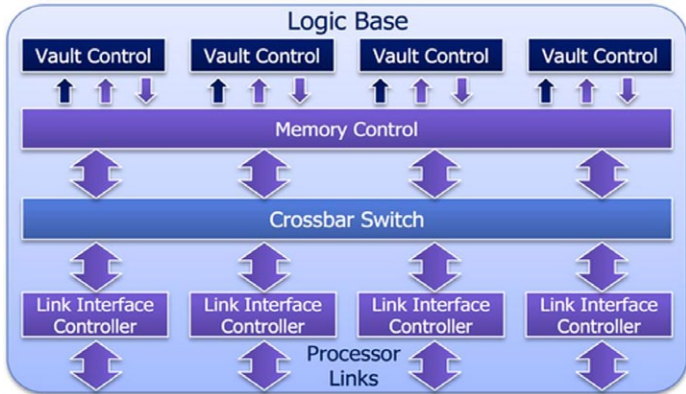

Micron 3D XPoint memory uses a resistive material between a highly dense crossbar array to change 0s to 1s with current. (Source: Micron)

# Spice up your Pi for IoT development

By Richard Quinnell

**D**evelopers seeking to enter the IoT market quickly discover that creating a nifty device is not enough. No matter how clever, the device is only one part of a larger system that includes such things as gateways, servers, analytics, web services, and even mobile apps. Developers without the resources to provide all these elements must find them elsewhere, which can make for integration challenges.

Something new has entered the market, though, which claims that it solve those challenges for you, especially if your device design is based on the Raspberry Pi.

Platforms that IoT developers can leverage to support their device designs are not new. Companies like Thing-Worx, Ayla Networks, Google, and Apple along with consortia like the Allseen Alliance are offering platforms that they hope will attract users and build an ecosystem of interoperable devices around their platform as a common standard.

But nearly all of the platforms available require the IoT device be custom designed and programmed to operate with that platform.

A company called myDevices offers an alternative. Its platform, released in late 2015, is device-agnostic, supporting a wide variety of wireless technologies as well as standard data communications protocols such as CoAP, MQTT, and the REST API. The platform will adapt to the device rather than forcing the device to conform to it. It will also let devices using the platform talk with one another, serving as a translator.

Whatever platform a developer chooses, however, there remains a lot of work to in order to create a device that can utilise the platform. That includes building and configuring the device, deciphering and coding for APIs to interact with the platform, and the like. Until now, that is.

myDevices has just released Cayenne, a tool for developers and makers to rapidly configure a complete IoT system, including mobile apps, rules engines, and analytics, starting with a widely-available development board – the Raspberry Pi. And you don't even need to work at configuring the Pi. Cayenne is designed to automatically discover any Pi connected to the same network as the host computer, then download its agents into the Pi. When the Pi reboots, it is ready to serve as the basis of an IoT device.

Cayenne provides developers with a host of capabilities for

turning that Pi into a fully functioning IoT system node. Cayenne will automatically detect any sensors connected to the Pi and make their data available on a drag-and-drop configurable data display dashboard in a choice of numeric and graphical formats. Another dashboard gives developers full access to the Pi's GPIO resources for rapid configuration and sensing. Triggers allow events on one device invoke action on another device, or send messages via SMS or email. The tool also automatically configures a mobile or web-based app to replicate the dashboard.

A mobile app with configurable widgets is automatically available when using Cayenne. In essence, with Cayenne serving as the front-end to its platform, myDevices has turned prototyping of a complete IoT system design using the Raspberry Pi from a lengthy process to a matter of minutes. (The company claims to get a Pi up and online in under seven minutes.) Best of all, developers can get started for free.

For makers creating unique devices or professional developers

developing a proof of concept, the approach can be a godsend with how much time, and error-prone effort it can save.

For professional developers using a different hardware approach, however, Cayenne may seem the wrong flavour.

But that may be a short-lived situation.

Kevin Bromber, CEO of myDevices, told me in a recent interview that the Raspberry Pi is only the beginning. He expects to be licensing his technology to hardware manufacturers to integrate with their devices, so that boards like BeagleBone, Launchpad, and other professional development platforms will also be able to use Cayenne and its associated platform. myDevices is currently working with LoRa manufacturers, for instance, to bring in their MCU boards, Bromber said.

He also indicated that an API is scheduled for release soon that will allow developers to bring in their custom boards.

With a platform and front end like myDevices and Cayenne, starting development for the IoT is going to become incredibly easy, promoting an explosion of innovative ideas.

Survival of those ideas in the market, of course, still requires a good business model, production-ready design, and a host of other business necessities. But those are well known challenges. What Cayenne does is to spice up the initial development phase, where an idea first becomes realised.

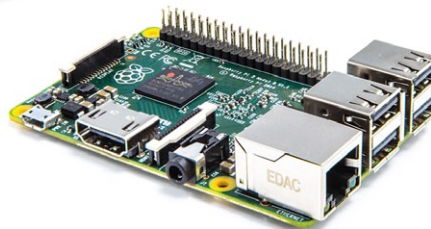



## PROTOTYPING & DEVELOPMENT BOARDS

### Segger bundles IDE, hardware and middleware elements

Segger has released its Embedded Studio PRO offering, a platform that combines the company's Embedded Studio development environment, along with a selection of its key embedded software components, a J-Link PLUS debug probe, plus an emPower evaluation board. Segger Embedded Studio is designed to provide all tools needed for professional embedded development. Supporting all

major operating systems (Windows, Mac OS X and Linux), it presents a comprehensive solution for the implementation of embedded applications (with source code editing, compiling and debug functionality all encompassed).

Further components include the embOS RTOS with zero latency, the emFile robust file management system, the emWin GUI for any application that operates with a graphical LCD, the embOS/IP TCP/IP stack for Internet connectivity and the emUSB USB stack with host and target side support.

**Segger**

[www.segger.com](http://www.segger.com)



## RV-8063-C7 Real-Time Clock Module with SPI Bus

Automotive qualified, according to AEC-Q200 Rev. C,  
Size: 3.2 x 1.5 x 0.80 mm,  
Temperature range:  
-40°C to +85°C,  
100% leadfree,  
RoHS-compliant  
[www.microcrystal.com](http://www.microcrystal.com)



MICRO CRYSTAL SWITZERLAND

A COMPANY OF THE SWATCH GROUP

Our authorised distributor WDI AG is pleased to assist you.

+49 4103 1800-0 [microcrystal@wdi.ag](mailto:microcrystal@wdi.ag) [www.wdi.ag/microcrystal](http://www.wdi.ag/microcrystal)

TFT-LCD Modules

Perfect view –  
in every situation:

TFT-LCD modules from  
Mitsubishi Electric.

Visit us at the trade fair:

**embedded world**

February 23–25, 2016

Hall 1, booth 181

**Beyond Expectation:** TFT-LCD modules from Mitsubishi Electric set a new standard in the field of industrial use. Designed for high reliability, optimal visibility and enhanced viewing ability even under strong sunlight, Mitsubishi Electric TFT-LCD modules, in combination with our unique PCAP Touch Panel Technology, ensure best performance with excellent picture quality. For this reason professional users choose TFT-LCD modules from Mitsubishi Electric.

More information: [lcd.info@meg.mee.com](mailto:lcd.info@meg.mee.com) / [www.mitsubishichips.eu](http://www.mitsubishichips.eu)

**With Super High Brightness, Glass Bonding and Super Wide Viewing Technology**

- Long term support
- Real transfective technology
- Robust mechanical design (up to 6.8 G)
- Wide temperature range (-40 °C up to +85 °C)
- One stop PCAP solution (with integrated controller)
- Super high brightness (up to 1,500 cd/m<sup>2</sup>)
- Special formats (e.g. square, ultrawide)

**MITSUBISHI  
ELECTRIC**  
*Changes for the Better*

# Implementing an IoT end-point SoC platform with minimal engineering resources

By Tim Whitfield

A typical system for the Internet of Things (IoT) is likely to comprise a number of 'end-point' devices that integrate sensors and tiny processors with enough built-in intelligence and communication ability to collect and send data from their environment and also potentially take action.

These devices will be connected via low-power wireless networks, which will also require intelligence for management and functionality, via internet gateways and up into the cloud, where a mass of collected data can be accessed by mobile devices or analysed for IoT use cases.

For these IoT applications to be successful, crucial characteristics of end-point devices are very low cost – cents rather than dollars – and minimal energy consumption: devices will be powered by coin-cell batteries or scavenge energy from their environment and will need to last months or years rather than hours, days or weeks. A further typical characteristic of end-point devices is that they will usually be in sleep mode with infrequent communication. Further application requirements include security, which is absolutely crucial in the IoT, and it must start within the end-point device and from there through the network and into the cloud. Furthermore, application software deployment on devices needs to be easy to access and control for maintenance and updating system or device parameters. Systems will need to be highly scalable and operate efficiently whether there are just a few or thousands of devices in the network.

## Challenge – three engineers in three months

As in any electronics market – given sufficient demand for volume production – the advantages delivered with the integration of functionality on system-on-chip ICs (SoCs) include BOM-cost savings, robustness, size and power efficiency.

Unlike leading-edge mobile consumer devices such as smartphones, however, IoT products and especially end-point devices such as sensor-based environment-monitoring systems will require a completely different performance/power profile, with low energy consumption typically being the overriding consideration.

In a proof-of-concept project, ARM set itself a challenge in 2015 to demonstrate that the physical implementation of an SoC for an IoT end-point device with strict low-power and cost constraints is easily attainable for small design groups from companies of almost any size, including start-ups as well as large OEMs/ODMs. Furthermore, the goal was to develop a platform and prototype a test chip that would enable their design teams to rapidly build differentiated solutions by integrating varying combinations of ARM IP with their own IP.

The project should also demonstrate the potential of ARM's platform for IoT to minimize risk, while also reducing cost and

accelerating time-to-market with only minimal engineering resources. One further goal was for ARM to gain a better understanding of the challenges of design and IP implementation for IoT devices – for example, it was an integration-first in a design for the company's new Bluetooth radio IP together with embedded Flash.

The specific task was to rapidly implement this prototype silicon demonstrator platform – called Beetle – with only three engineers and in less than three months. Finalised and taped out in Q3 2015, the resulting platform integrates ARM IP on a single piece of silicon and includes an IoT subsystem with Cortex-M microprocessor, Bluetooth 'Smart' Low-Energy (BLE) radio, plus embedded Flash memory – see figure 1.

The Beetle being a test chip, minimal optimisations were performed for area or power management.

But even without significant effort, initial benchmarking and analysis were in line with similar ARM Cortex-M3 based devices. The ARM Cordio radio operates in the sub 1 Volt region as per design, and therefore allows extremely low power communication.

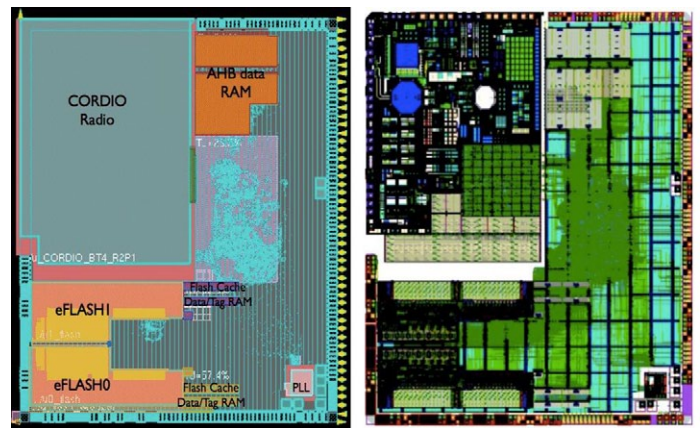

Fig. 1: The Beetle test chip die and its different elements.

This test chip was built using the ARM Artisan physical IP platform specifically tailored for IoT applications. The design is also fully compliant with ARM's mbed IoT platform to enable rapid development and prototyping.

## Platform building blocks

Shown in figure 2 is the ARM IoT device demonstrator platform, which is implemented in TSMC's 55nm process technology and runs mbed OS software. A central element of the platform is the IoT Subsystem, which was launched in mid-2015 and is designed to work with the Cortex-M3 processor or the Cortex-M4 for more demanding applications that require DSP instructions.

A second key piece is the ARM Cordio BLE radio, which incorporates the Bluetooth Core Specification Version 4.2 and is a best-in-class prequalified 'hard macro' block for rapid integration by designers familiar with digital design environments and

Tim Whitfield is Director of Engineering at ARM's Hsinchu Design Centre – [www.arm.com](http://www.arm.com)





**Touch and 3D Gesture Control**



# Touch and 3D Gesture Control

Microchip's award winning technologies cover a broad range of implementations for touch and 3D control applications—from touch buttons (1D) to touch screens (2D), as well as 3D gesture control.

Microchip has the solution for your user interface needs, including:

- Water-resistant touch buttons
- Heavy duty touch solutions under metal
- Lower-power touch pads
- Non-touch interaction based on hand gestures



## Keys, Sliders and Proximity

User interfaces with push buttons have several moving parts, which significantly decrease their reliability. They also require complex design and assembly as well as a major investment in tooling. Microchip touch technologies, such as capacitive or Metal-over-Capacitive (MoC), allow you to create a high-impact user interface at a lower total system cost.

- Easy to use
  - Turnkey, bus or digital I/O interface
  - Microcontroller based
- Robust
  - High SNR (Signal to Noise Ratio)
  - IEC61000, EFT and BCI tested
- Lowest Power
  - Proximity sensing down to 1  $\mu\text{A}$
  - Capacitive Sensing down to 5  $\mu\text{A}$

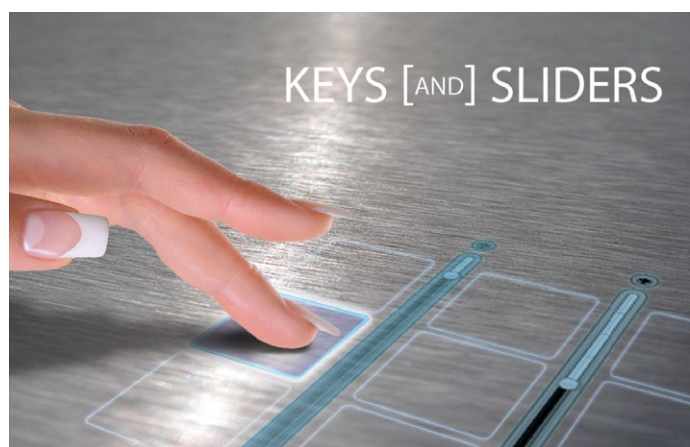

## Capacitive Touch Sensing

### How It Works

A capacitor is simply two electrically isolated conductors which are in close proximity to one another. The conductors can be wires, traces on a PCB or even the human body. The capacitive touch sensor is a copper pad area that is capacitively coupled to grounds located elsewhere in the system creating a parasitic capacitance. A covering plate material such as glass is used to provide the user touch surface. The introduction of the user's finger then produces an increase in capacitance which will be detected by the system.

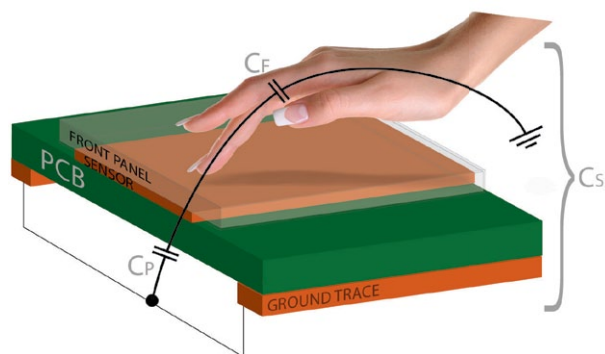

### Microcontroller-Based Solution

Microchip offers a variety of standard PIC® MCUs enabling you to dedicate an MCU for touch function or integrate touch sensing with other application functions onto a single MCU:

- 8-, 16- and 32-bit PIC MCUs for touch sensing
- From 6-pin to 144-pin devices
- Up to 512 KB Flash memory
- On-chip integration options include USB, CAN, IrDA, wireless protocol stack, segmented LCD and graphics accelerator and LCD driver for TFT/STN displays

### Low-Cost mTouch® Evaluation Kit (DM160227)



The Low-Cost mTouch Evaluation Kit provides a simple platform for developing capacitive touch sense applications using including water-resistant touch.

### mTouch Capacitive Touch Software Package

The mTouch Software Package enables designers to easily integrate touch technologies into their application. It allows the implementation in a small dedicated controller as well as integration of the complete application in a single MCU.





# Keys, Sliders and Proximity

## Turnkey Solutions



The MTCH10X capacitive touch controllers provide the fastest and simplest way to evolve from mechanical buttons to modern touch. Designed for direct button replacement, the MTCH10X family provides dedicated digital output for every input channel while implementing latest noise suppression technologies.

- From 1 to 8 sensors
- Water resistance
- Proximity
- Packaging as small as 2 × 3 mm DFN

### MTCH10X Evaluation Board (DM160229)



The MTCH10X Evaluation Board provides an out-of-the-box experience for performance and the robustness of Microchip touch solutions.

The CAP1XXX capacitive touch controllers provide a wide variety of slider, button and proximity functionality. A Graphical User Interface (GUI) allows the designer to analyze sensor data and easily configure the controller.

- From 1 to 14 sensors
- Up to 11 LED drivers
- Enhanced proximity option with guard ring
- I<sup>2</sup>C or SPI communication
- 1.8–5.5V
- As small as 2 × 3 mm TDFN or optimized for manufacturing as SOIC.

### CAP1188 Evaluation Board (DM160222)



The CAP1188 evaluation kit provides an easy platform for evaluating and developing a variety of capacitive touch sense applications and LED configuration using CAP11XX family.

### CAP1298 Evaluation Board (DM160223)



The CAP1298 evaluation kit provides an easy platform for evaluating and developing a variety of capacitive touch sense and proximity applications using CAP12XX family.

## Metal-Over-Capacitive Technology

In addition to capacitive touch, Microchip has developed metal-over-capacitive technology enabling:

- Metal surfaces such as stainless steel or aluminum
- Sense through glove support
- Waterproof designs
- Braille-friendly interfaces

Metal-over-capacitive technology is implemented with the same Microchip hardware, PCB, electronics and firmware as capacitive touch technology.

### How It Works

A metal-over-capacitive touch system uses a conductive target layer suspended over a capacitive touch sensor, to act as a second capacitor plate. When the user applies a downward pressure on the target, the resulting deformation moves the center of the target closer to the capacitive sensor. The change in spacing produces a change in capacitance, which is then measured by the touch controller.

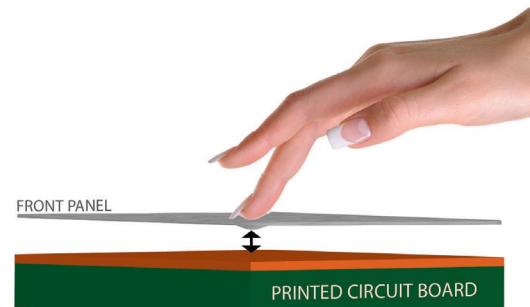

The target can be a sheet of metal with the Fascia marking screen on the outer surface, a metal flashing on the back of a plastic fascia, or a co-molded layer composed of both metal and plastic. The spacer layer is typically an adhesive with a cut out over the capacitive sensor, and the sensors themselves can be either printed conductive pads on a plastic film or pads etched into the top surface of a PCB.

## Application Notes

- *Techniques for Robust Capacitive Touch Sensing*, AN1334
- *mTouch Sensing Solution Acquisition Methods Capacitive Voltage Divider*, AN1478
- *Proximity Design Guide*, AN1492
- CAP1XXX Capacitive Touch Controller Tuning Guide, AN2034
- *mTouch Metal-Over-Cap Technology*, AN1325 and AN1626
- *Capacitive Touch Using Only an ADC (CVD)* (suitable for PIC10/12/16/24H/32 MCUs), AN1298

For datasheets, user's guides and general design information please visit [www.microchip.com/touch](http://www.microchip.com/touch).



# Touch Pad and Touch Screen Controllers

## Touch Pad and Touch Screen Controllers

Microchip offers a broad portfolio of touch solutions for touch screen and touch pad applications that make it easy for designers to integrate touch-sensing interfaces.

- High-flexibility
  - We offer both turnkey and source code touch solutions with options to integrate touch sensing with application code on a single low-cost MCU
- Sophisticated
  - Advanced touch solutions use sophisticated proprietary touch decoding algorithms to send your application fully processed and reliable touch coordinates
- Easy Integration
  - Add touch technology to your application without extensive development time, risk or cost
  - On-board surface gesture detection (multi-finger scroll, swipes, tap events, etc.) allow even GPIO-based integration
  - Lowest power

## Projected Resistive and Capacitive Touch Solutions

Microchip offers both projected capacitive and resistive touch solutions to allow you to choose the best fit for your design. Each offers different advantages:

### Analog Resistive

- Low-cost sensors that accept finger, glove or stylus inputs
- Ease of manufacturing and integration

### Projected Capacitive

- Glass front sensor construction provides high durability, good optics and light touch
- Multi-touch capability which enables gestures

## Touch Sensing Technology Comparison

	Analog Resistive	Projected Capacitive
Cost for screen < 6"	Lowest	Low
Cost for screen > 10"	Lowest	High
Optics	75%	90%
Screen Life	Good	Better
Ease of Integration	Easy	Moderate
Multi-Touch	Limited	Yes
Touch Object	Finger, Stylus/ Glove	Finger

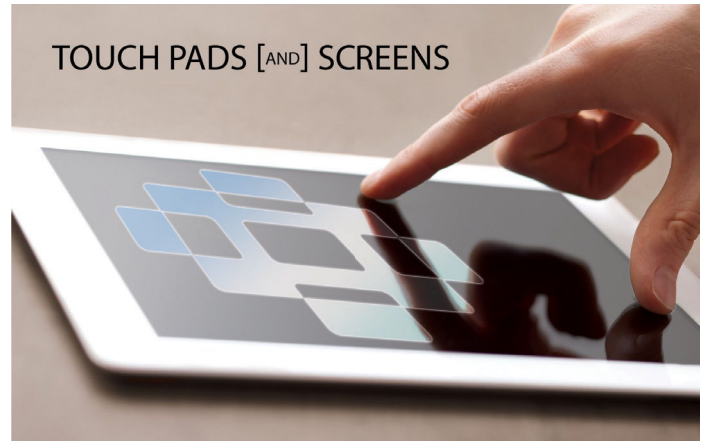

## Resistive Technology Overview

### How It Works

Two conductive coated polyester layers are separated by a spacer layer. When touched, the top (flex) layer moves past the spacer layer and contacts the bottom (stable) layer. The point of contact creates a voltage divider in the X and Y directions.

### AR1000 Resistive Touch Advantages

- Proven plug-and-play design
- Eliminates all host processing of touch data
- Built in decoding and advanced filtering
- Low system power—wake on touch
- Universal, supports all 4-, 5-, and 8-wire sensors
- SPI, I<sup>2</sup>C, UART or USB Interfaces
- Free drivers for most major platforms

### Development Tools for Resistive Touch

Microchip provides fully functional hardware and feature-rich GUIs to quickly get started using AR1000 resistive touch controllers for a turnkey, cost effective solution.



mTouch AR1100  
Development Kit  
(DV102012)



mTouch AR1000  
Development Kit  
(DV102011)





# Touch Screen and Touch Pad Controllers

## Projected Capacitive Technology

Microchip's projected capacitive technology is available as turnkey touch controllers or solutions across the portfolio of 8-, 16- and 32-bit PIC microcontrollers. You can use a dedicated controller for touch or integrate additional applications with touch into a single MCU. Our flexible, royalty-free source code and turnkey projected capacitive touch controllers provide you with solutions to create the innovative user interfaces that consumers desire.

### Lowest Power Touch Pads: MTCH6102

Microchip offers key advantages in touch pad design with low-power and low-cost solutions to enable simple touch designs with short time-to-market. Microchip leverages eXtreme Low Power (XLP) technology to provide industry-leading low power touch solutions to maximize battery life. Example power measurements for a typical application with 11 channels using the MTCH6102 at 2V are:

- Standby <1  $\mu$ W
- Approach <30  $\mu$ W
- Active <300  $\mu$ W



### How It Works

Projected Capacitive Touch Sensors operate by measuring the tiny change in capacitance on an electrode due to the influence of a human finger or other object.

- One or two thin conductive layers
- Screen is configured as rows and columns
- Point of contact identified by change in capacitance of row and column cells electrodes

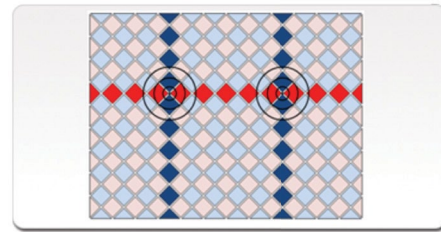

### Included Gestures

All turnkey controllers (MTCH61XX/MTCH63XX) detect (multi-)finger gestures.

- |              |                   |                     |                      |
|--------------|-------------------|---------------------|----------------------|
| Single Tap   | Swipe Up          | Swipe Down and Hold | Swipe Right          |
| Double Tap   | Swipe Up and Hold | Swipe Left          | Swipe Right and Hold |
| Tap and Hold | Swipe Down        | Swipe Left and Hold |                      |

## Development Tools for Projected Capacitive Touch

Microchip makes it easy to add gestures and multi-touch to your interface design.

### MTCH6102 Low-Power Projected Capacitive Touch Pad Development Kit (DM160219)



- Supports the MTCH6102
- Surface gesture detection on board
- GUI with skins to accelerate UI development

### MTCH6303 Multi-Touch PCAP Development Kit (DV102013)

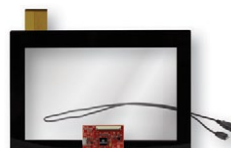

- Supports the MTCH6303
- Ten-finger multi-touch
- Multi-finger surface gesture detection on board
- GUI provided for system integration
- Convenient direct USB interface
- 8" ITO sensor included

For datasheets, user's guides and general design information please visit [www.microchip.com/touch](http://www.microchip.com/touch).



# 3D Tracking and Gesture Sensing

## MGC3030/3130 3D Gesture Controllers with GestIC® Technology

The MGC3030/MGC3130 are single-chip solutions to enable 3D gesture control in almost any product, such as wireless speakers, radios, light switches and remote controls. The MGC3x30 are optimized for embedded usage, require no host intelligence or resources and come with a complete gesture portfolio.

### The Benefits of GestIC Technology

Similar to capacitive touch sensing, GestIC technology uses E-field sensing to detect gestures. Electrodes remain invisible behind the device housing, allowing an aesthetically pleasing industrial design without the need for holes or other cut-outs typically required for cameras or infrared-based systems. Further benefits include:

- Full surface coverage, no blind spots
- Lighting independent
- Build in adaptive noise filtering
- Only gesture solution with built-in auto wake/sleep
  - <100 µA sleep current
- Low system complexity
- Low costs

The MGC3030/MGC3130 output direct and immediately usable results—everything is detected on-chip including gestures, approach, touch events and x/y/z 3D positions. The MGC3x30 controllers are true single-chip solutions for the next generation of user interface, enabling gesture-based UI applications for embedded products.



### Fast, Precise and Robust

Implemented as a low-power mixed-signal System-on-Chip (SoC), the MGC3x30 controllers offer a rich set of smart-functional features including:

- 0 (touch) to 10 cm detection range
- Fast report rate up to 200 Hz (5 ms)
- Field upgradable on-board gesture suite
- Digital interface (I<sup>2</sup>C) and configurable GPIOs

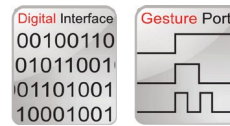



## On-Board Gesture Recognition

Gesture recognition is performed on chip to eliminate the complexity and need for additional processing, a unique feature to GestIC technology shortening your time-to-market. The gesture suite gives the MGC3030/MGC3130 controllers the ability to recognize gestures while the rest of the system is powered down or in a power savings mode. It is field-upgradable to ensure your system can accommodate and use additional gesture algorithms as they become available.

### Gestures

 **Approach Wake-up** is primarily used to wake up the MGC3130 (and the rest of the system) when a hand approaches the sensing area.

 **Flick Gestures** are available as swipes or edge flicks in four directions: North, East, South and West. These are typically used for commands such as next, previous, on/off or up/down.

 The **Airwheel Gesture** is an intuitive input for up/down adjustments to levels and values. The rotations are also detected on chip.

 **Sensor Touch** detects touch, tap or double tap at any of the five receive electrodes. This is typically used for selection and confirmation commands.

Like speech and language, everybody's hand gestures have a unique quality that differs in timing, amplitude and a broad range of other metrics. The integrated GestIC Technology Colibri Suite makes use of a Hidden Markov Model for high recognition rates of various gestures. This detects the subtle difference between deliberate gestures and general hand movement to limit response to unintended gestures.

 The **Wave Gesture** registers small finger movements and differentiates in the x- and y-direction. Applications include shuffle play control in an audio device.

 The **Hold Gesture** detects a steady hand to trigger events, best envisioned as the touchless enter key. Timing is configurable.

 The **Presence Gesture** enables intelligent back lighting and in the simplest manner.

 **Position Tracking** is available on the MGC3130.



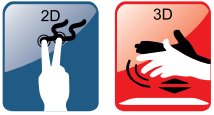

# Gesture Sensing and Multi-Touch

## 3DTouchPad: 2D Multi-Touch Pad with 3D Gesture Sensing



The 3DTouchPad (DM160225) converges Microchip's 2D projected capacitive touch solution with Microchip's patented GestIC technology for 3D gesture recognition.

The 3DTouchPad is a PC peripheral that extends the 2D touch pad with 3D gestures. The 3DTouchpad offers multi-finger tracking and surface gestures as well as free-space 3D gestures above the surface.

The 3DTouchPad is a powerful accessory to enhance your productivity by providing gestures to interact with your PC as well as a compelling development platform.

Microchip provides an SDK/API for app/driver development as well as a Graphical User Interface (GUI).

For more information, please visit [www.microchip.com/3dtouchpad](http://www.microchip.com/3dtouchpad).

## 3D Gestures for 2D Multi-Touch Displays



Gestures are a powerful way to enhance the user interface of a product. They are simple to use and simple to perform.

With Microchip, you can now go even further by adding 3D gestures to multi-touch displays. By combining 10-finger, multi-touch sensing with 3D gestures up to 20 cm from the display, the touch display we all embrace becomes sensible for the third dimension. Interaction with gloves, prevention of smudging and touchless interaction can all become a reality.

Features include:

- MTCH6303-based 2D multi-touch sensing
- 10-finger touch sensing
- >100 Hz report rate
- Extended gesture range of up to 20 cm
- Complete 3D gesture suite available

Please contact Microchip Sales or Marketing for details.

## Evaluation Tools

### MGC3130 Hillstar Development Kit (DM160218) and MGC3030 Woodstar Development Kit (DM160226)

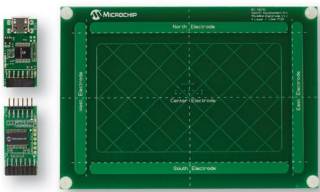

These kits are a complete modular solution for designing in the low-cost, high-performance MGC3030/3130. System parameterization is guided by Microchip's AUREA (GUI).

Features:

- 5" electrode and variety of electrode reference designs
  - GestIC technology electrode design guide
  - MGC3030/3130 unit (GestIC Technology Colibri Suite)
  - I<sup>2</sup>C/USB bridge (USB powered)
- GestIC Technology interface library manual
  - I<sup>2</sup>C interface reference code
  - Microchip's AUREA GUI for Windows 7 and Windows 8
  - SDK for Windows 7, Windows 8, Windows 10, Android™ and Linux® operating systems

For datasheets, user's guides and general design information please visit [www.microchip.com/gestic](http://www.microchip.com/gestic).

## Support

Microchip is committed to supporting its customers in developing products faster and more efficiently. We maintain a worldwide network of field applications engineers and technical support ready to provide product and system assistance. In addition, the following service areas are available at [www.microchip.com](http://www.microchip.com):

- **Support** link provides a way to get questions answered fast: <http://support.microchip.com>
- **Sample** link offers evaluation samples of any Microchip device: <http://sample.microchip.com>
- **Forum** link provides access to knowledge base and peer help: <http://forum.microchip.com>
- **Buy** link provides locations of Microchip Sales Channel Partners: [www.microchip.com/sales](http://www.microchip.com/sales)

## Sales Office Listing

### AMERICAS

**Atlanta**  
Tel: 678-957-9614

**Austin**  
Tel: 512-257-3370

**Boston**  
Tel: 774-760-0087

**Chandler**  
Tel: 480-792-7200

**Chicago**  
Tel: 630-285-0071

**Cleveland**  
Tel: 216-447-0464

**Dallas**  
Tel: 972-818-7423

**Detroit**  
Tel: 248-538-2250

**Houston**  
Tel: 281-894-5983

**Indianapolis**  
Tel: 317-773-8323

**Los Angeles**  
Tel: 949-462-9523

**New York**  
Tel: 631-435-6000

**San Jose**  
Tel: 408-735-9110

**Toronto**  
Tel: 905-673-0699

### EUROPE

**Austria - Wels**  
Tel: 43-7242-2244-39

**Denmark - Copenhagen**  
Tel: 45-4450-2828

**France - Paris**  
Tel: 33-1-69-53-63-20

**Germany - Dusseldorf**  
Tel: 49-2129-3766400

**Germany - Munich**  
Tel: 49-89-627-144-0

**Germany - Pforzheim**  
Tel: 49-7231-424750

**Italy - Milan**  
Tel: 39-0331-742611

**Italy - Venice**  
Tel: 39-049-7625286

**Netherlands - Druenen**  
Tel: 31-416-690399

**Poland - Warsaw**  
Tel: 48-22-3325737

**Spain - Madrid**  
Tel: 34-91-708-08-90

**Sweden - Stockholm**  
Tel: 46-8-5090-4654

**UK - Wokingham**  
Tel: 44-118-921-5800

## Training

If additional training interests you, then Microchip can help. We continue to expand our technical training options, offering a growing list of courses and in-depth curriculum locally, as well as significant online resources – whenever you want to use them.

- Technical Training Centers and Other Resources: [www.microchip.com/training](http://www.microchip.com/training)
- MASTERS Conferences: [www.microchip.com/masters](http://www.microchip.com/masters)
- Worldwide Seminars: [www.microchip.com/seminars](http://www.microchip.com/seminars)
- eLearning: [www.microchip.com/webseminars](http://www.microchip.com/webseminars)

### ASIA/PACIFIC

**Australia - Sydney**  
Tel: 61-2-9868-6733

**China - Beijing**  
Tel: 86-10-8569-7000

**China - Chengdu**  
Tel: 86-28-8665-5511

**China - Chongqing**  
Tel: 86-23-8980-9588

**China - Dongguan**  
Tel: 86-769-8702-9880

**China - Hangzhou**  
Tel: 86-571-87928115

**China - Hong Kong SAR**  
Tel: 852-2943-5100

**China - Nanjing**  
Tel: 86-25-8473-2460

**China - Qingdao**  
Tel: 86-532-8502-7355

**China - Shanghai**  
Tel: 86-21-5407-5533

**China - Shenyang**  
Tel: 86-24-2334-2829

**China - Shenzhen**  
Tel: 86-755-8864-2200

**China - Wuhan**  
Tel: 86-27-5980-5300

**China - Xiamen**  
Tel: 86-592-2388138

**China - Xian**  
Tel: 86-29-8833-7252

**China - Zhuhai**  
Tel: 86-756-3210040

### ASIA/PACIFIC

**India - Bangalore**  
Tel: 91-80-3090-4444

**India - New Delhi**  
Tel: 91-11-4160-8631

**India - Pune**  
Tel: 91-20-3019-1500

**Japan - Osaka**  
Tel: 81-6-6152-7160

**Japan - Tokyo**  
Tel: 81-3-6880-3770

**Korea - Daegu**  
Tel: 82-53-744-4301

**Korea - Seoul**  
Tel: 82-2-554-7200

**Malaysia - Kuala Lumpur**  
Tel: 60-3-6201-9857

**Malaysia - Penang**  
Tel: 60-4-227-8870

**Philippines - Manila**  
Tel: 63-2-634-9065

**Singapore**  
Tel: 65-6334-8870

**Taiwan - Hsin Chu**  
Tel: 886-3-5778-366

**Taiwan - Kaohsiung**  
Tel: 886-7-213-7828

**Taiwan - Taipei**  
Tel: 886-2-2508-8600

**Thailand - Bangkok**  
Tel: 66-2-694-1351

1/27/15



Microcontrollers • Digital Signal Controllers • Analog • Memory • Wireless

Information subject to change. The Microchip name and logo, the Microchip logo, GestIC and PIC are registered trademarks of Microchip Technology Incorporated in the U.S.A. and other countries. mTouch is a registered trademark of Microchip Technology Incorporated in the U.S.A. All other trademarks mentioned herein are property of their respective companies. © 2015, Microchip Technology Incorporated. All Rights Reserved. DS00001599C. ML2173Eng12.15



**MICROCHIP**  
[www.microchip.com](http://www.microchip.com)

Microchip Technology Inc.  
2355 W. Chandler Blvd.  
Chandler, AZ 85224-6199



design flows. Designed for optimum efficiency with Cortex-M processors, it features a sub-1V low-power core and its BLE radio offers leading-edge power consumption of less than 6.5mW (@1V) in active (Tx/Rx) mode and 700nW in sleep mode.

Complementing these elements are the ARM Artisan standard cell, SRAM and general-purpose I/O physical IP libraries.

Device, communication and lifecycle security is primarily delivered via the ARM mbed IoT Device Platform, which includes the open-source mbed OS and the mbed Device Connector Service, which handles communication with IoT end-point devices. mbed is supported by more than 50 mbed ecosystem partners offering a host of compatible components, cloud services and software tools, and has been adopted by more than 150,000 developers worldwide.

The main device security aspect is primarily handled via mbed OS  $\mu$ Visor, which creates isolated security domains on the Cortex-M processor using its Memory Protection Unit (MPU), and communication security is handled via mbed TLS (Transport Layer Security). In many IoT applications device security must be augmented with additional features in hardware: for example, the Beetle demonstrator SoC implements ARM's TRNG (True Random Number Generator) in hardware.

### Integration

Implemented using a standard digital design flow and tools, the platform can enable digital design teams that have little know-how in the integration of radio or embedded flash to meet highly aggressive development timescales with minimal engineering resources. Layout guidelines are available to developers: essentially delivering integration capabilities for engineers with primarily digital experience.

Including timing and physical abstract models, the use of an EDA-tool-agnostic physical design kit (PDK) significantly mitigates the challenge of radio integration – engineers do not require extensive mixed-signal/RF expertise and in fact, the BLE radio can essentially be treated as a digital IP block.

Integration takes a relatively straightforward hard-macro-like approach with an all-digital interface to the host controller and standard AMBA-AHB bus interface for easy integration to the Cortex-M IoT subsystem. The asynchronous design also removes the dependency on clock timing between the radio and host control.

Other features of the implementation include use of sideband signals for radio power and clock control; a built-in pad ring for the radio I/O, to simplify integration and to help the critical and noise-susceptible radio I/O.

The integrator needs only to follow some basic integration guidelines to ensure sufficient noise isolation such as sufficient decoupling of the power supplies and guard-banding to avoid substrate noise.

To simplify this further macro blocks of decoupling metal-oxide-metal (MOM) capacitors were created to provide an area efficient bulk decoupling capacitor for the supplies as well as comprehensive guidelines for guard-banding against substrate noise between the radio and digital logic. To simplify design, the radio design requires minimal external components with just seven capacitors, two inductors, two crystals and an antenna.

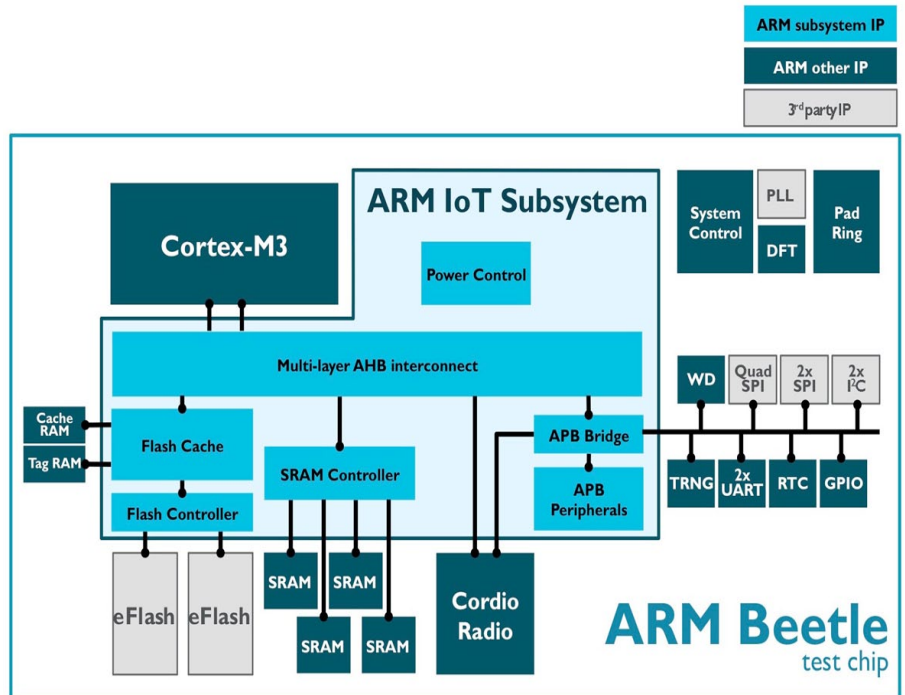

Fig. 2: ARM IoT Device Demonstrator Platform – The “Beetle” test chip

The design also integrates embedded flash IP (from TSMC), which was a first experience of embedded flash for the design team and presented a more complex challenge than integrating SRAM blocks for example. It brings the requirement to use voltage-level shifting between the sub-1V logic domain and flash memory, which requires 1.2V/2.5V supply levels for its read/write operations. The ARM Artisan physical IP platform provides both regular and thick-oxide versions of the level shifters, required for shifting to the 2.5V domain.

Even when optimised for low-power systems, the embedded flash memory accesses contribute significantly to the power consumption of the SoC, prompting the development and use of an embedded flash cache to reduce flash memory accesses to a minimum. Two banks of 128K were implemented in the Beetle test chip, which as an example could run application code in one bank with over-the-air code updates in the second. The cache and flash controller are part of the IoT subsystem, which could support up to 512K of flash for more complex nodes.

### Platform availability and evolution

The IoT subsystem for Cortex-M together with the Cortex-M3 processor, the Cordio radio, low-power Artisan physical IP libraries, embedded Flash hard macro (through TSMC), mbed Device Platform, plus an MPS2 development board are available now for rapid software and hardware prototyping and development.

The company is also looking to enrich its IoT development ecosystem to further enhance deployment and rapid prototyping of IoT devices. In conjunction with Thundersoft, ARM recently set up an IoT ecosystem accelerator in Beijing to offer workshops, training and design services to help IoT device makers from start-ups to OEMs.

In addition to the IoT components that have been used in the Beetle chip, ARM is proposing further security enhancements with the TrustZone CryptoCell IP. Artisan libraries for more advanced process nodes might also be used in the future to improve energy efficiency.

## Multi-purpose wearables: a makers' dream come true

By Julien Happich

**W**ith the CPRO version of its MetaWear sensing platform now raising funds on Kickstarter, Californian startup mbientlab is providing makers a Bluetooth-connected remote sensor on steroids. Only 3mm thick (CR2032 coin battery included) and 24mm in diameter, the open-source ambient sensor board measures acceleration, angular velocity, magnetic field, pressure, altitude, temperature and ambient light.

Designed around Nordic Semiconductor's nRF51822 SoC (featuring a 32-bit ARM Cortex M0 CPU) the device has enough on-board flash memory to log up to 15,000 sensor data entries before they are downloaded to a smartphone via the Bluetooth Low Energy radio module. Because the sensor unit is over-the-air programmable and updatable, controlled and programmed through a smartphone, it can be repurposed instantly, from one application to the next, as the ultimate wearable sensor.

Rather than being yet another mote hardware nicely packaged and marketed for one or two dedicated applications, the CPRO is open to feed any app with its versatile sensing capabilities.

The sensors on the BOM list include a LTR-329ALS ambient light sensor from LiteON, with a full dynamic range from 0.01 lux to 64k lux (16-bit resolution), a Bosch pressure and temperature sensor with redundant thermistor, and a 9-axis combo sensor from Bosch integrating an accelerometer, a magnetometer and a gyroscope. Interfacing pins include a PWM pin, an I2C

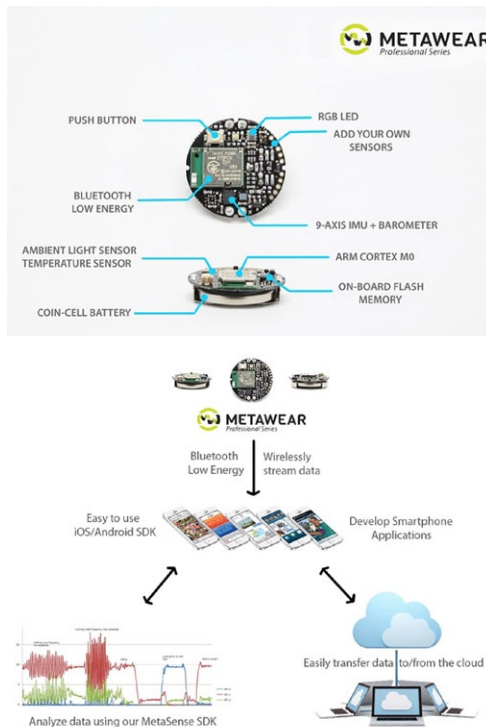

interface and four Analog/Digital general purpose I/O pins which could serve to attach additional sensors. A LED indicator and a push button switch mounted on the board complete the tiny unit.

To make their product the most versatile and easy to integrate, the engineers at mbientlab offers a complete 3D MCAD model for download so users can make their own case. In its MetaWearCPSv0.5 datasheet, the company proposes further options such as fitting a Bosch BME280 digital humidity sensor, an ams TSL26711 optical proximity sensor or an ams TCS34725 RGB colour sensor.

According to the designers, the integrated power management circuit ensures battery will last up to several months.

In the last 2 years, the startup has successfully crowdfunded two previous generations of BLE-connected sensor boards, raising over USD 115,000 early 2014 and an additional USD 50,622 early 2015.

But as a third iteration and rich from the feedback they got, the CPRO is more compact and packs more sensors and options.

A software development kit is also available for users to download and view their data, control the device, and create complex data filters or triggers based on sensor data.

But for those hackers who may not be too versed in complex data analysis, the startup also offers to do the data analysis, providing a cloud environment with machine learning tools and algorithm development solutions to extract meaningful information and contextualize your data with regard to your end application.

## Code-free IoT platform is open to control just anything

By Julien Happich

**W**iFiThing aims to put on the market a code-free Internet of Things (IoT) platform that the British startup hopes will allow just about anyone to connect smart devices around their home easily, without being tied to one brand or to one set of applications.

The open source IoT solution put forward on Kickstarter consists of a WiFi-enabled master board that monitors and control slave boards through a low-power ISM radio connection. Masters can control up to eight slave devices, four groups of FS20 radiator valves and 10 Orvibo Smart Sockets. Designed in sleek white plastic enclosures, both the master and slaves have over 20 I/O pins including digital and analog input and output. What's more, the WiFiThing slaves can communicate using I2C. More capabilities are under development, like Modbus.

Because the slave devices are controlled through the WiFi-enabled master, users can still control their appliances from their smartphone, communicating directly with the master (even



The WiFiThing units in their white cases.



# Critical Recording in Any Arena

## When You Can't Afford to Miss a Beat!



**FREE Evaluation!**  
SystemFlow  
Simulator

Introducing Pentek's expanded line of Talon<sup>®</sup> COTS, rugged, portable and lab-based recorders. Built to capture wideband SIGINT, radar and communication signals right out-of-the-box:

- Analog RF/IF, 10 GbE, LVDS, sFPDP solutions
- Real-time sustained recording to 4 GB/sec
- Recording and playback operation
- Analog signal bandwidths to 1.6 GHz
- Shock and vibration resistant Solid State Drives
- GPS time and position stamping
- Hot-swappable storage to Windows<sup>®</sup> NTFS RAID5
- Remote operation & multi-system synchronization
- SystemFlow<sup>®</sup> API & GUI with Signal Analyzer
- Complete documentation & lifetime support

Pentek's rugged turn-key recorders are built and tested for fast, reliable and secure operation in your environment.

Call 201-818-5900 or go to [www.pentek.com/go/eettalon](http://www.pentek.com/go/eettalon) for your FREE *High-Speed Recording Systems Handbook* and *Talon Recording Systems Catalog*.



**PENTEK**  
Setting the Standard for Digital Signal Processing



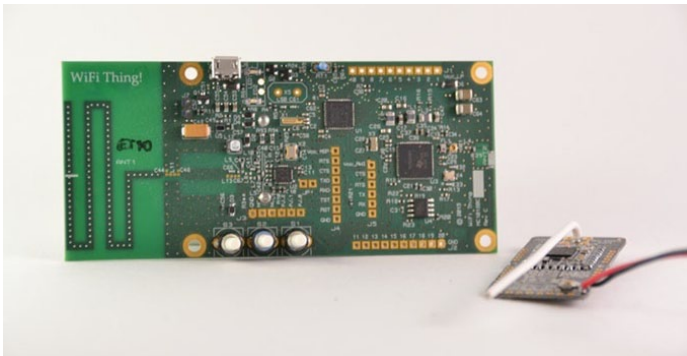

The bare WiFiThing master and slave side by side.

in the case they lose their Internet connection).

The company has created 60 built-in functions in the master and slave devices and each function has up to four parameters. All these are configured via the company's secure webserver, using simple drop down menus. These functions give end-users full control over the devices, including controlling the radios, setting up and reading/writing to pins, storing and doing calculations on data, conditional functions, timers and communications with the web server.

Beyond the initial hardware purchase, the code-free aspect comes at a cost, that of using WiFiThing's website and web App for a small monthly fee, £1 per month after the first 3 months free of charge.

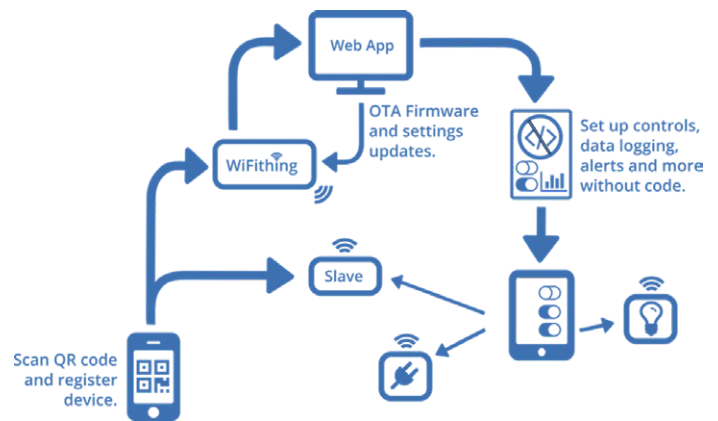

Web-based configuration for over-the-air updates.

But since all the code on WiFiThing and controlling the slaves is open source and documented, there is still the option for any confident programmer to recode their WiFiThing units to point to their own website, or alternatively to use the company's secure API to send and receive settings and data from their WiFiThing and slaves, either from a desktop application or another website. You could even modify the original code or create your own and update your devices over the air. For developers, the company provides an Emulator software program (and its source code) which can emulate either a Master device or can communicate through the API.

### GPS tracker leverages SigFox' network

French startup HidnSeek has made the first customer deployments of its GPS tracking solution launched through Kickstarter last year. Deployed and tested

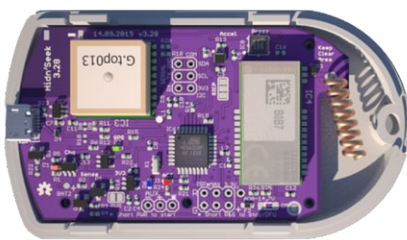

for several months across multiple European countries, the small HidnSeek tracker does not require an expensive GSM connection, or proximity to Bluetooth devices which would limit range. It communicates its position to the end-user through SigFox's IoT network. The device comes with customizable open apps, allowing users to geolocate objects in real-time, to define parameters to track movement and boundaries, and to set alerts. Applications include tracking lost equipment, detecting possible accidents and motionless states, tracking drone paths or landing sites, or securing property by detecting unauthorized movement. There is a €19.90 annual service charge. For the makers out there, the 100% Arduino compatible GPS is also available as a board with USB cable. The open source design is built around Atmel's AVR 328p CPU (12Mhz), Telecom Design's TD1207 Sigfox modem, and a GlobalTop PA6H GPS module.

**HidnSeek**  
[www.HidnSeek.com](http://www.HidnSeek.com)

### Nucleo development boards support ST's 32-bit Flash MCUs

With the introduction of the STM32 Nucleo-144 series of low-cost, compact development boards, STMicroelectronics has further extended

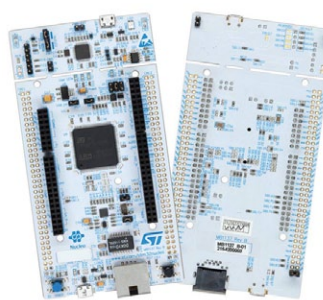

its support for its STM32 family of 32-bit Flash microcontrollers. The new 144-pin boards enhance the existing STM32 development ecosystem through increased connectivity that enables customers to quickly develop applications using any STM32 microcontroller, from the most power-efficient to the highest-performing devices. The new boards are fully compatible with the existing STM32 development ecosystem, including the range of dedicated plug-in application expansion boards that allow specialized features ranging from motor drives to motion and environmental sensors to be easily incorporated into the final application. The offer unlimited extension capability via three types of connector: in addition to the Arduino Uno and ST morpho connectors provided by existing Nucleo-64 boards, the new boards include an ST zio connector. Together, these three connectors give complete access to all of the STM32 general-purpose I/O pins, allowing easy implementation of any creative function. Selected STM32 Nucleo-144 boards include Ethernet, as well as USB FS OTG ports to ease connections to local/wide area networks. All of the STM32 Nucleo-144 boards include an integrated ST-Link debugger/programmer, which eliminates the need for a separate debug probe, and are compatible with the most popular development toolchains. The new boards will be ARM mbed-enabled during Q2 2016, giving customers free access to ARM mbed online tools that do not require any software installation.

**STMicroelectronics**  
[www.st.com](http://www.st.com)



## PROTOTYPING & DEVELOPMENT BOARDS

### Temperature and relative humidity readings via Bluetooth

Mouser Electronics is now stocking the SHT31 Smart Gadget development kit from Sensirion. The Smart Gadget is a reference design circuit board and development kit that demonstrates the performance and ease-of-use of Sensirion's SHT3x series



humidity and temperature sensors. It shows relative humidity ( $\pm 2$  percent accuracy), dew point, and temperature in Celsius (accurate to 0.3 degrees) or Fahrenheit (accurate to 0.5 degrees), all on a small integrated LCD screen. It can also communicate these values wirelessly with a Bluetooth® Smart capable device, such as a smartphone or tablet. The reference design helps developers begin projects with an environmental sensor, Bluetooth connectivity, and corresponding apps. The Smart Gadget supports two debug interfaces as well as I2C and SPI protocols.

**Mouser Electronics**  
[www.mouser.com](http://www.mouser.com)

### Evaluation kit helps digitalize your power supply

Würth Elektronik eiSos GmbH & Co. KG and Infineon Technologies AG have launched the jointly developed "XMC Digital Power Explorer" evaluation kit, a synchronous step-down converter which can be assembled with two different control cards (XMC1300 - ARM Cortex-M0 MCU and XMC4200 - ARM Cortex-M4F MCU), for developers of analog power supplies and embedded software programmers to enter the world of digital power supply. Developers can compare two performance classes using two different control cards. The high-performance XMC4200 family offers a high-resolution PWM

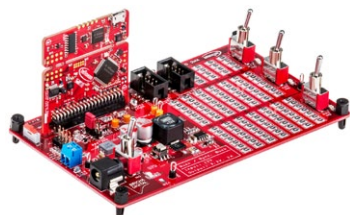

unit (with 150 ps resolution) and intelligent analog comparators with precise slope compensation that can considerably simplify power supply design. The XMC1300 family, on the other hand, is cost-optimized to provide excellent cost effectiveness for simpler power supply applications.

The high-performance XMC4200 family offers a high-resolution PWM unit (with 150 ps resolution) and intelligent analog comparators with precise slope compensation that can considerably simplify power supply design. The XMC1300 family, on the other hand, is cost-optimized to provide excellent cost effectiveness for simpler power supply applications.

**Würth Elektronik eiSos GmbH & Co. KG**  
[www.we-online.com](http://www.we-online.com)

### Cloud enabled secure IoT solution kit leverages NXP's LPC43S67

The LPC43S67 & A7001CM Cloud Connectivity Kit offers a high-performance, dual-core ARM Cortex processor along with IC-enabled security and add-on boards



affording the designer a range of IoT features like NFC, AES128/192/256 encryption, WiFi connectivity, Ethernet, accelerometer, gyroscope, temperature sensor, and an LCD. It is a great platform for anyone experimenting with IoT or cloud-backed mobile applications. Beyond the target hardware, which includes the LPCXpresso43S67 board with LPC43S67 dual-core (M4F and M0+) MCU and NXP A7001CM Secure Element, NTAG NDC plug-in card, LPC General Purpose Shield (hosting an accelerometer, gyroscope, temperature sensor, joystick and LCD), IEEE 802.11b/g SD card, this kit is supported by NXP's LPCXpresso IDE and ZentriOS – a complete connected product operating system available as a licensable software solution.

The Zentri SDK, can be easily combined with the rich editing and debugging capabilities of the LPCXpresso IDE by installation of a free plugin. Debugging is simplified by LPCXpresso43S67's on-board Link2 probe, which provides full source code debugging capability without the need for any additional hardware.

**NXP**  
[www.nxp.com](http://www.nxp.com)

**HARWIN**  
INTERCONNECT DESIGN & MANUFACTURE

## 50 Ohm Coax for High-Rel applications



High-Reliability Coax connectors for cable-to-board and board-to-board applications.

- Single body moulding resists shock and vibration

- 2, 4, 6 & 8 positions

- Designed for use with RG178 cable

- Features locking screws for secure connection

- PCB fixings offer mechanical strength

- Tested to 100g shock\*

\*test reports available

**Datamate Coax**

For more information visit

[www.harwin.com/datamate-coax](http://www.harwin.com/datamate-coax)

# Shrinking UWB for mass adoption

By Nick Wood and Christopher Barratt

Ultra-Wide Band (UWB) has for some time been the “Cinderella” technology of the RF world – seemingly never quite receiving an invite to the wireless party that has been in full swing over the last decade. Whilst Bluetooth, WiFi, GPS and 4G are well known to the average teenage smartphone user, even industry insiders can return with a quizzical look when the UWB acronym is thrown into conversation.

The technology has been around since 1901 when Marconi used spark gap radio transmitters to send Morse code data across the Atlantic, so it isn't new. Current UWB uses the unlicensed bands between 3 and 8 GHz, so in theory offering up a nice chunk of increasingly crowded spectrum to play with. What has been less clear is what to do with it.

Various use-cases have been tried without finding any real market traction. Wide-area networking, high speed WiFi, ultra-fast “contactless” data transfer have all been mooted as applications. A number of silicon vendors (Staccato, Alereon, Wisair, and more) have come and gone pinning their success on the technology.

Perhaps the diversity of possible applications has been one of the problems, because UWB is not really a standard, but more a method of radio transmission. In essence, UWB is a technology for transmitting information spread over a large bandwidth; this should, in theory and under the right circumstances, be able to share spectrum with other users. In more precise terms FCC and the International Telecommunication Union Radiocommunication Sector (ITU-R) currently define UWB as an antenna transmission for which emitted signal bandwidth exceeds the lesser of 500 MHz or 20% of fractional bandwidth.

Now there is a new wave of interest in UWB, but with the application this time being precise distance measurement and indoor positioning. There's a real optimism that this time UWB may have found a niche that it can really claim as its own.

Of course, after the false starts, a degree of scepticism might be in order, but there are some good reasons to think this is the right use-case for the technology.

To start with, the ubiquity of GPS means positioning solutions are widespread, and so the concept is well understood, with a plethora of software and systems already developed. But GPS sometimes doesn't provide the necessary accuracy, and of course may stop working altogether inside buildings.

Nick Wood is President of Insight SiP – [www.insightsip.com](http://www.insightsip.com) – he can be reached at [nick.wood@insightsip.com](mailto:nick.wood@insightsip.com). Christopher Barratt is Chief Technical Officer at Insight SiP – he can be reached at [chris.barratt@insightsip.com](mailto:chris.barratt@insightsip.com)

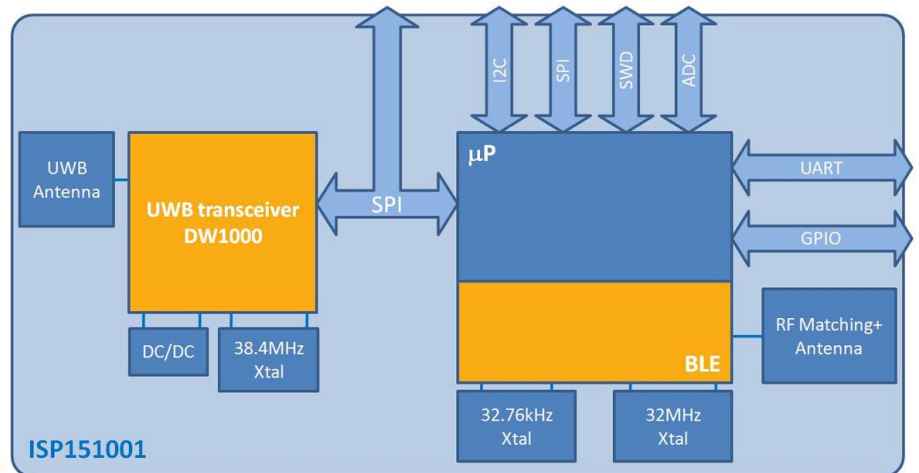

Fig. 1: Insight SiP's ISP151001 module combines an UWB transceiver, Smart Bluetooth and an ARM Cortex M4 processor, packed with the necessary antennas in 9x19x1.5mm package.

There are other solutions for indoor positioning – using Bluetooth beacons, or Wi-Fi access points for example – but frankly, these don't work very well. These solutions are based on signal strength, and there are simply too many factors that can vary signal strength by 50% or more (for example the orientation of a smartphone).

By contrast, UWB positioning is based on time of flight measurement of an extremely narrow pulse, so it can achieve high accuracy, and is not sensitive to variations in signal strength. The result is that one can achieve accuracy of 10 centimetres with UWB, over measurement distances of up to 50m, whereas signal strength based methods struggle to achieve accuracy of greater than +/- 1m, over a much shorter range.

One further advantage of this method can be found in the domain of security – another hot topic of the day. Many cars these days have keyless entry systems, which effectively detect proximity of the key through signal strength.

Boris Danev and his associates have shown (in a real practical experiment, not just theoretically) that these systems can be often quite easily be hacked via a “relay-attack” with off the shelf electronics. A UWB-based system is resistant to this kind of attack, as the time of flight method of distance measurement is extremely hard to fake. The same applies to other wireless entry systems.

These concepts may be interesting, but to implement solutions, working technology is needed. Fortunately there are a number of vendors supplying them. On the silicon side, the most advanced is the Irish vendor Decawave, which already has its first chip on the market (DW1000), and is already working on the next generation.

However there are others such as BeSpoon and 3DB Technologies following on behind, and the big players of the silicon world are keeping a close eye on the market, ready to step in at the first signs of real traction.



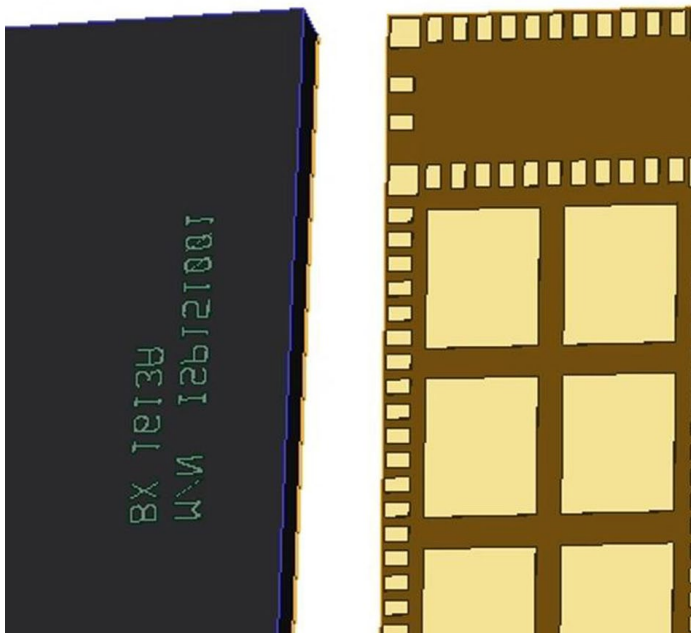

Fig. 2: The ISP151001 UWB Smart Bluetooth module measuring 9x19x1.5mm.

Silicon is not enough on its own, though. Customers need a complete working solution, and the RF design required to generate wide-band transmissions over a large spectral range are far from trivial. Here RF module specialist Insight SiP is providing solutions, offering a fully functioning, certified module complete with integrated antenna, based on the Decawave solution, with others to be offered when silicon is available.

Insight SiP has been working on UWB technology for several years, in particular tackling the challenging antenna issues involved in working with such a wide frequency band. The UWB spectrum is divided in two for regulatory purposes (the unimaginatively named 3-5 GHz “low-band” and 5 to 8 GHz “high-band”). Not all territories permit use of both bands, so any solution for global markets has to be flexible enough to use either band on demand.

Insight SiP has developed a range of innovative miniature antennas that fit directly above the RF components in small system in package (SiP) modules. Combining the antenna with the electronics in a single package makes deployment of UWB as simple as mounting a single QFN style device on a PCB.

There are a number of companies starting trials with the technology, with applications in automotive, warehousing and asset tracking. Gemalto, the secure element vendor, is leading a large European project that uses the technology to combine

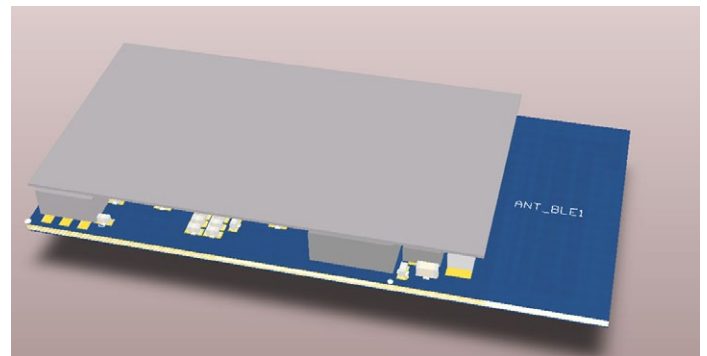

Fig. 3: Outline of the ISP151001 module showing the antenna. secure data exchange with accurate positioning.

There seems little doubt there will be a market for the technology – the question is more how big it can be. The holy-grail for the vendors of course would be for the technology to be adopted inside the phone. This may be a little way off, but being able to accurately and securely position a phone could open up a number of interesting use-cases – for instance payments, or passing an airline boarding gate, but without having to take the phone out of your pocket. What past history has shown is that if a wireless technology proves useful, it migrates inside the phone quite quickly.

In the short term it will be standalone solutions that kick-start the market. Nevertheless, UWB is back, with a new role and a new lease of life, and it's the wireless technology to watch for the second half of the decade.

Insight SiP has designed an extremely small integrated SiP combining UWB, Smart Bluetooth and an ARM Cortex M4 processor, together with both UWB and Bluetooth antennas in a small package whose size is only 9x19x1.5mm.

The module is based on the Decawave DW1000 transceiver and the Nordic Semiconductor nRF52 Smart Bluetooth ASIC. A smaller variant of the product that does not include the Smart Bluetooth function is also available, measuring 9x15x1.5mm.

The ISP151001 outline is shown in figure 2: it has a 43% smaller footprint than the original PCB based Decawave reference module that only includes the transceiver, the antenna and the crystal; yet it is 50% thinner.

The small size of the complete solution is possible thanks to the combination of very dense SiP assembly on a state of the art SiP substrate. This is coupled to a proprietary over IC antenna design that is integrated into the package in the same way as a metal shield. Figure 3 shows an outline of the module with the position of the antenna.

 <p><b>MERCURY+ SA2</b> Altera® Cyclone® V SoC Module</p> <p>from €286*</p> 	 <p><b>MERCURY ZX5</b> Xilinx® Zynq™-7015/7030 SoC Module</p> <p>from €160*</p> 	<p><b>Everything FPGA.</b></p> <p> Hall 4A, 121</p> <p> ENCLUSTRA FPGA SOLUTIONS</p> <p><small>*High volume price, subject to change.</small></p>
--	--	---

# How to address the communications challenges of Smart Meters

By Emmanuel Gresset

**T**he communication and connectivity requirements of smart meters and other 'smart energy' equipment and devices present significant challenges for designers and developers. Let's identify the communications challenges of Smart Meters and understand how current generations address them today. We will then consider how they should be addressed in order to offer practical and cost-effective and future proof smart grid solutions.

The diagram below shows examples of smart grid network architectures and will help understand why flexibility and multi-mode are key attributes of any new generation Smart Meter deployment.

Solutions are diverse and based on numerous technologies depending on geographies, local standards and quality of network infrastructure.

The HAN (Home Area Network) or BAN (Building Area Network) uses short range wireless standards such as ZigBee, Thread, WiFi and Bluetooth to connect home appliances to smart meters. It may also use PLC (Power Line Carrier) wireline technology.

The NAN (Neighborhood Area Network) uses either a star network topology such as cellular M2M (GPRS, 3G, LTE MTC, NB-IoT, LPWAN) to connect each meter directly to the base-station and the cloud or a mesh network topology such as PLC or 802.15.4g to aggregate all smart meter nodes to a DAP (Data Aggregation Point) that will be connected directly to the base-station with cellular M2M (GPRS, 3G, LTE MTC) or directly to the cloud via Ethernet.

## Flexibility

Flexibility is a must to support all the standards listed above, some of which are still under development and will require updates and remote upgrades in the field.

PLC for example, has been standardized by multiple standardization bodies such as IEEE P1901.2, PRIME (PowerLine Intelligent Metering Evolution) and G3 all of which offer multiple variants for data rates and frequency bandwidth. Countries have also derived variants of PLC to optimize them to the specifics of their electrical power networks.

To date there are still no universally agreed interoperability standards governing smart grid communications and there will probably never be one!

### Multi-mode

Multi-mode is also mandatory as most use-cases require multiple functions to run concurrently. The mesh NAN topology deployed in European and Asian cities calls for concurrent PLC and 802.15.4g as a node may be connected to one node via PLC and to another node via 802.15.4g at the same time.

## Extreme low power

While electric smart meters have mains power, non-electric meters must run 5 to 10 years on two AA batteries which requires

very careful optimization of both idle and peak power consumption.

### Very low cost

To enable fast and widespread deployment of electric smart meters, the complete HAN/NAN communication module bill of material (BOM) should be in the \$15 to \$20 range.

Existing communication solutions use hardware centric modems which cannot be upgraded to track standards evolution and country variants and cannot support field updates.

Therefore Multimode systems are heterogeneous because they consist of a piecemeal collection of independent hardware-based modems. Such heterogeneous solutions are sub-optimal from a power, performance, cost and area standpoint. They also require longer time to market.

Software Defined Modems (SDM) are required to address these challenges with low cost and low power solutions. These modems should run on a unified high performance processor that can run multiple PHYs & Protocols with a true RTOS to support concurrency while minimizing task switching and MAC to PHY latencies.

And at the heart of these flexible communications engines are programmable DSP architectures, such as CEVA-XC5 and CEVA-XC8 that, by supporting a variety of communication standards, allow the developer to implement software-defined modems with no extra hardware requirement.

Not only do such architectures reduce time to market but they also minimize risk by offering future-proof solutions that can evolve over the product lifetime by upgrading firmware in the field as standards evolve. Software only country to country customizations allow economies of scale which reduce further the system solution BOM.

## Next step: "Smarten" and connect other meters

To make these systems even more challenging, the diagram above shows only a third of the worldwide smart meters, namely the electric meters.

Indeed, today, the Smart Grid has been focusing mostly on smart electric meters but the next step is to "smarten" and connect all other meters which include water meters, hot water meters and gas meters.

Although these other meters only need to transmit a few bytes uplink per day and even less downlink, they are more challenging to interconnect than electric meters because they have no built-in power and therefore need a very low power connection that can last 5-10 years without battery recharge.

They may also be located in difficult to reach places such as a basement, underground or under water, where radio access may be a challenge.

Therefore the link budget needs to be very high and will dictate which technology to choose. For these reasons, the only technology contenders are Cellular MTC (Cat-M, NB-IoT), LPWAN (such as LoRa, Sigfox, ...) and WiFi 802.11ah.

Emmanuel Gresset is Business Development Director, Wireless at CEVA - [www.ceva-dsp.com](http://www.ceva-dsp.com)



# Millimeter-band CMOS chip communicates at 56Gbps

By Julien Happich

**T**okyo Institute of Technology and Fujitsu Laboratories Ltd. Have jointly developed a CMOS wireless transceiver chip that can process signals at up to 56Gbps, a world's first, across a broad range of frequencies, from 72 to 100GHz.

Millimeter-waveband (30-300 GHz) could bring high-capacity wireless communications in places where fibre-optic networks would be difficult to lay. But designing CMOS integrated circuits running at such high frequencies remain a challenge. The two labs were able to design low-loss transceiver circuits that modulate and demodulate broadband signals into and out of the millimeter-waveband, connecting the circuit board to the antenna.

First, Tokyo Institute of Technology developed a technology for broadband, low-loss transceiver circuits in which data signals are split in two, with each converted to different frequency ranges, and then recombined.

Each signal is modulated into a band 10-GHz wide, with the low-band occupying the 72-82 GHz range, and the high-band occupying the 89-99 GHz range. This technology enables modulation on an ultra-wideband signal of 20 GHz, with low noise and a similar range in the ratio between input and output power as existing 10 GHz band methods, which results in high-quality signal transmissions.

The research institute also developed an amplifier to send and receive radio waves signals converted to the millimeter-waveband. The ultra-wideband amplifier for 72 to 100 GHz was designed with circuit technologies that stabilize the amplification ratio by feeding the amplitude of the output signal back to the input side for signal components whose amplification ratio decreases based on frequency.

The signal converted to the millimeter-waveband by the semiconductor chip is transported over the circuit board's signal path and supplied to the antenna. Because the antenna is made out of a waveguide (a metallic cylinder), there needs to be an ultra-wideband, low-loss connection between the printed circuit board and the waveguide.

Fujitsu Laboratories and Tokyo Institute of Technology developed an interface between the circuit board and waveguide that uses a specially designed pattern of interconnects on the printed circuit board to adjust the impedance for the ultra-wideband range, enabling loss in the desired frequency range to be greatly reduced. Performing indoor data-transfer tests with two modules facing each other separated by a distance of 10cm, the Japanese researchers achieved data-transfer rates of 56 Gbps, the fastest wireless transmission speeds in the world, with a maximum loss of 10% between the waveguide and circuit board. Fujitsu Laboratories aims to have a commercial implementation of wireless trunk lines for cellular base stations around 2020.

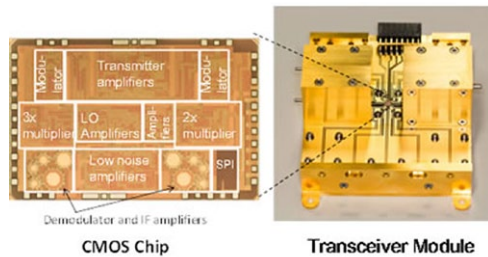

# Comms Solutions

From CML Microcircuits

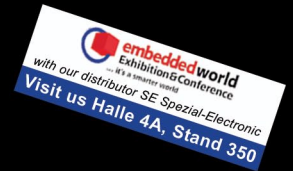

## Wireless Data Modems

- Multi-modulation
- Embedded protocol
- Advanced Coded Modulation (ACM)



## RF Building Blocks ICs

- Direct conversion ICs
- I/Q modulators/demodulators
- Transceivers
- Tx PA linearisation



Visit [www.cmlmicro.com](http://www.cmlmicro.com)



THE ORIGINAL SINCE 1994  
**PCB-POOL**  
 Beta LAYOUT

## Flex PCB Prototypes & Small Series

**NEW!**

**Flexible PCBs:**

- Favourable pricing – thanks to PCB-POOL® production
- Online Calculation
- Made in Germany

Email: [sales@pcb-pool.com](mailto:sales@pcb-pool.com)

[www.pcb-pool.com](http://www.pcb-pool.com)

Beta LAYOUT create:electronics

PCB-POOL® is a registered trademark of Beta LAYOUT GmbH

### Four-antenna path beamforming CMOS transceiver supports up to 4.62Gbps

At last IEEE International Solid-State Circuits Conference (ISSCC2016), nanoelectronics research center imec and Vrije Universiteit Brussel (VUB) presented a four-antenna path beamforming transceiver for 60GHz multi Gb/s communication in 28nm CMOS technology. The transceiver is a breakthrough in developing a small, low-cost, and low power solution for multi-gigabit communication targeting WiGig as well as 60GHz wireless backhaul applications. Imec's and VUB's 60GHz transceiver architecture features direct conversion and analog baseband beamforming with four antennas. The researchers say the architecture is inherently simple and is not affected by image frequency interference. A 24GHz phase-locked loop that sub-harmonically locks a 60GHz quadrature oscillator is inherently immune to the pulling disturbance of the 60GHz power amplifier, they add. The prototype transceiver chip, only 7.9sqmm is implemented in 28nm CMOS and integrates a four-antenna array. The chip was validated with a IEEE 802.11ad standard wireless link of 1m. The transmitter consumes 670mW and the receiver 431mW at 0.9V power supply. The transmitter-to-receiver EVM was better than -20dB in all the four WiGig frequency channels (58.32, 60.48, 62.64 and 64.8 GHz), with a transmitter equivalent isotropic radiated power (EIRP) of 24dBm. This allows for QPSK as well as 16QAM modulations according to the IEEE 802.11ad standard, achieving very high data rates up to 4.62 Gbps.

**imec**  
[www.imec.be](http://www.imec.be)

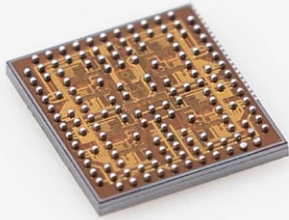

### 55x20x3.5mm dev module packs LoRa, WiFi and Bluetooth

Pycom's second project on Kickstarter, LoPy is a WiFi, Bluetooth and LoRa (Low Power WAN) enabled module supporting 10x faster programming with MicroPython scripting. Developed



as a follow-up project from Pycom's original WiPy Kickstarter feedback (where 60% of backers expressed their preference for a new WiFi and Bluetooth module and 20% for a new WiFi and LoRa module), the LoPy not only has all three, but it also doubles up as a LoRa Nano Gateway, able to connect up to 100 other LoPys in a 5km radius. The Amsterdam-based startup has formed partnerships with LoRa network operators like Senet and ThingsNetwork to give LoPy users the best possible network coverage. LoPy uses MicroPython's open source scripting language to reduce microcontroller coding time, greatly decreasing the time to market for connected products. The company will make available ready to use coding templates all editable with the Pymakr IDE to be launched in March. The multiple radios allow the LoPy to bridge data across a smartphone and the LoRa network.

**Pycom**  
[www.pycom.io](http://www.pycom.io)

### Highly stable and flexible SAR testing for wireless devices

The MT8820C Radio Communication Analyzer from Anritsu Corporation now integrates with both DASY6 and cSAR3D from Schmid & Partner Engineering AG (SPEAG) to provide seamless Specific Absorption Rate (SAR) compliance testing that significantly



reduces assessment costs and maximizes flexibility. The measurement of RF exposure, expressed in terms of SAR, is a mandatory testing requirement in many countries, bringing with it a need for cost effective, accurate and reliable testing that reduces time to market.

DASY6 is the latest generation of the industry-leading dosimetric and near-field evaluation system. It is fully compliant with all international standards and national regulations for SAR measurement. Compared to DASY52, DASY6 includes powerful new features resulting in a significant time savings for routine SAR compliance testing. This is achieved without sacrificing accuracy by combining robot-optimized movements, intelligent scanning and smart utilization of

standardized test reduction techniques. The integration of the MT8820C Radio Communication Analyzer improves the efficiency of user handling to save even more time during the certification process.

To improve measurement speed, cSAR3D uses state-of-the-art fast data acquisition, advanced 3D field reconstruction algorithms, and tight integration of the Anritsu MT8820C Radio Communication Analyzer. cSAR3D is designed for testing compliance with national and international exposure guidelines. It is compliant with the latest draft of IEC 62209-3 and it uses fast SAR protocols defined in IEC 62209-2 and IEEE 1528. cSAR3D integrates with DASY6 for the optimum combination of speed, versatility and regulatory acceptance.

The MT8820C One-Box Tester is a multi-format 2G, 3G, and LTE tester with capability for UE calibration, RF parametric testing, and functional testing, including call processing or no-call based testing. Supported formats include LTE-A, LTE, W-CDMA/HSPA CDMA2K up to 1xEV-DO Rev. A, TD-SCDMA/HSPA, and GSM/GPRS/EGPRS. The MT8820C provides the most stable and most widely proven implementation of cellular standards for base station emulation and RF TRX testing.

**SPEAG**  
[www.speag.com](http://www.speag.com)



### 3G/2G cellular module comes in 16x26x3mm 96-pin LGA package

u-blox' SARA-U201 3G/2G cellular module supports both 2G and 3G connectivity from a 16x26x3mm, 96-pin LGA package. The voice and data capable device provides 5-band UMTS, quad-band GSM, and has global radio regulatory approvals. It is pin-to-pin and form factor compatible with its 2G counterpart SARA-G350. It includes UART and USB



data communication interfaces and can be seamlessly combined with any u-blox GNSS modules and chips, thanks to its pre-integrated AssistNow client. Software stack and protocol support includes a dual stack IPv4 / IPv6, embedded TCP/IP, Ethernet over USB and BIP/eSIM support.

**u-blox**  
[www.u-blox.com](http://www.u-blox.com)

### Modular router connects railway passengers to Internet

The NB3800 Railway Router is Netmodule's latest product addressing passenger WiFi and infotainment applications. The mobile access is accomplished through multiple LTE modems as well as through IEEE 802.11ac WiFi modules. In addition to its wireless capabilities the Railway Router is equipped with five Ethernet interfaces; two of them have gigabit bandwidth.



What's more, the product also comes with solid-state disks (SSD) with capacities up to 1 terabyte, enabling the operator to provide offline content such as travel-related information, service information

or entertainment material. Another novelty form Netmodule is the NB3711, an expanded and extended version of the proven NB3710 Router. Like the NB3800, it is designed for railway deployment, connecting the passenger's smartphones and tablets via WiFi and LTE to the Internet. As an additional option the NB3711 can be equipped with a GSM-R module, enabling it to connect directly to the railway operator's communications infrastructure. CAN and IBIS interface modules are available to monitor the on-board electronic systems as well as to the passenger information systems. In addition, a GNSS satellite navigation module enables the operator to precisely locate the vehicle. All NetModule routers are implemented as modular systems, enabling system integrators to configure individual solutions. For instance, multiple LTE wireless modules can be utilised to achieve channel bundling or transparent hand-over between providers. The NetModule routers will be exhibited at the Embedded World trade fair (February 23 through 25 in Nuremberg).

**Netmodule**  
[www.netmodule.com](http://www.netmodule.com)

### Dual SMD antenna caters for LF and NFC

Premo Group has designed a single-package 3D-coil antenna with dual functionality, suitable both for Low Frequency (125 kHz) and High Frequency applications (13.56MHz).



Embedded in the 17.5x16.0x4.0mm 2D1D15 Series are 2D orthogonal coils featuring high surface resistance NiZn ferrite core material (over 10Mohm/mm) with medium initial permeability. This provide a very stable performance in a wide range of temperature (-40°C to +85°C). The 2D1D15

Series is offered with 4.77mH at 125kHz and 6uH at 13.56MHz as standard inductance values. This antenna can be ordered with custom inductance parameters to fit the desired performance. The new antenna meets AEC-Q-200, one of the most restrictive quality standards for electric components in automotive applications.

**Premo**  
[www.grupopremo.com](http://www.grupopremo.com)



## Business meets technology

- Join your community and benefit from
- **Networking**—Where manufacturers and end users come together.
  - **Knowledge transfer**—Research that inspires product ideas.
  - **Industry orientation**—State of the art technology that reveals market opportunities.

This is the place where printed electronics come to life.



**Book your ticket now!**  
[lopec.com/tickets](http://lopec.com/tickets)



©: FlexEnable Ltd (top), Takaco Someya Group, University of Tokyo (bottom left), Thiriflin, Norway (bottom right)

**Exhibition: April 6–7, 2016**  
**Conference: April 5–7, 2016**

Messe München, Germany



### Design & simulation software speeds realisation of RF circuits

The latest release of Keysight Technology's RF simulation and synthesis software, Genesys 2015, features Keysight Sys-Parameters that enables RF system simulation with off-the-shelf component datasheets; and comprehensive RF circuit synthesis to enable the fastest realisation of RF systems and circuits. Keysight Sys-Parameters define RF system component parameters such as amplifier P1dB, IP3, gain and noise-figure over frequency, temperature and bias in a convenient spreadsheet format that designers can use directly in RF system simulation. This eliminates the tedious creation of non-standard data files or writing of custom programs to interpolate the data; addressing a long unfulfilled need of the RF industry to use component datasheet specifications in fast design simulations instead of wasteful prototyping iterations. Genesys 2015 accepts multi-dimensional Sys-Parameter data in a regular spreadsheet format that a user creates from RF component datasheets. The software also provides Sys-Parameter libraries from Mini-Circuits and Analog Devices. Easy access to Sys-Parameters during design enables designers to accurately evaluate and select available RF system components before hardware implementation, thereby eliminating wasteful iterations. Genesys 2015 includes tutorial videos for its comprehensive suite of automatic RF circuit synthesis capabilities. The tutorials are designed to teach users how to quickly design and realise circuits such as filters, matching networks,

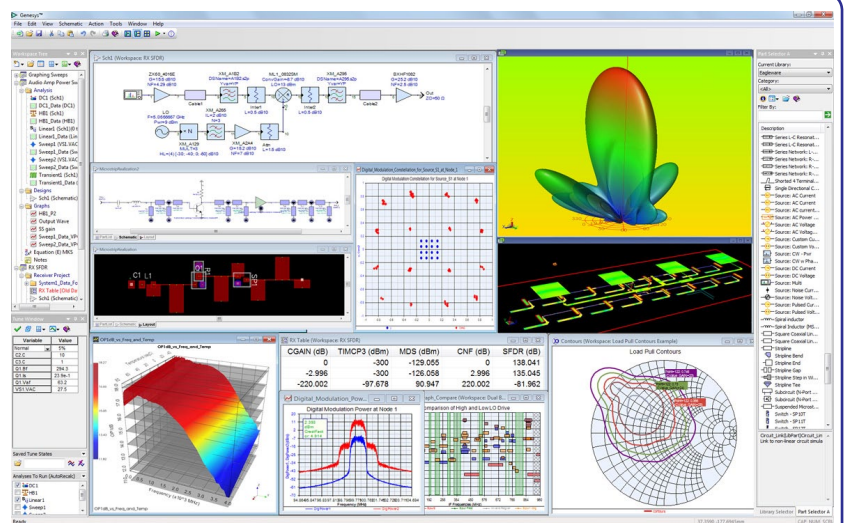

oscillators, mixers, couplers and transmission lines. Genesys 2015 also features a Matlab script debugger, multi-dimensional interpolator and interactive 3D graphing. These features expand Genesys programming, data processing and plotting capabilities to give the user complete control over the use of measured and simulated data. Genesys 2015 expands on its X-parameter vendor model library offering with reference-plane calibrated drop-in modules from X-Microwaves that guarantee the accuracy of simulation with final hardware implementation. Additional upgrades to Genesys 2015 include a new Momentum planar electromagnetic simulator and 3D layout viewer with interactive open/short detection.

**Keysight EEsop EDA Software**  
[www.keysight.com](http://www.keysight.com)

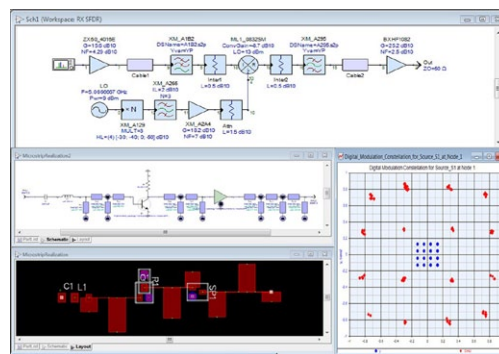

### Intermediate frequency adjustable coils offer inductances from 0.05uH to 150mH

Total Frequency Control Ltd offers I.F. adjustable coils in many different designs and sizes; either for generic replacements, standard or custom wound, tuneable shielded or unshielded. Designed for oscillator circuits or as an IF transceiver for AM/FM applications, these adjustable inductor coils are custom wound and manufactured with short lead times to meet sample and production requirements. The company offers drop-in replacements against many popular manufacturers with an inductance range between 0.05 micro H to 150milli H and an operating frequency range between 10 kHz and 200MHz. The product provides a high Q component with good resistance to shock and vibration with moulded variants and a range of core materials including carbonyl, ferrite, aluminium and brass.

**Total Frequency Control Ltd**  
[www.tfc.co.uk](http://www.tfc.co.uk)



### Flexible antennas target positioning applications

Antenova Ltd has added two new positioning antennas, Bentoni and Asper, to its range of flexible FPC antennas. Bentoni is a positioning antenna for all of the global public satellite constellations: GPS, GLONASS, Beidou and GALILEO. It is designed to be used in trackers, portable devices, network components, drones and wearable electronics. Asper is a dual antenna with two separate antenna systems in a single form factor. It combines a 1559 – 1609 MHz antenna with a 2.4 – 2.5 GHz antenna in the same part for positioning applications with wireless connectivity as well. This antenna is suitable for sports cameras, trackers, dash cams, portable devices, network devices and wearable electronics. Both antennas offer high performance and maintain good isolation in situ within a device. Bentoni and Asper are the latest flexible FPC antennas in Antenova's flexiiANT product range. They are supplied with an I-PEX MHF connector and a 1.13 mm RF cable in a choice of three lengths. They can be folded to save space in operation within a device.

**Antenova**  
[www.antenova-m2m.com](http://www.antenova-m2m.com)

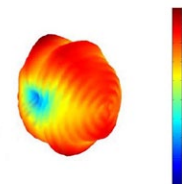



### Bluetooth Smart ready for prototyping in through-hole 16-pin DIP package

U.S. maker and hobbyist startup 'OSHChip' ('Open Source Hardware') now supplies a Nordic Semiconductor nRF51822 SoC in a unique 16-pin DIP package with IC-like through-hole pins. In addition to eliminating the need for soldering, the 19.8x8.9mm Bluetooth Smart module claimed to be less than 5 percent the size of an Arduino UNO

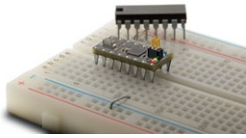

or 22 percent the size of an Arduino Nano. OSHChip can be programmed and de-bugged (Keil) from a partner OSHChip programmer board that supports USB drag-and-drop programming, SWD debugging, and bi-direction serial communications. The company plans to make the entire OSHChip module open source (including sharing its schematics, Gerber file, and BOM). Over-the-air programming functionality and sample apps for iPhone and Android will also be added in the near future.

**OSHChip**  
[www.oshchip.org](http://www.oshchip.org)

### Virtual drive testing toolset features simulated network support

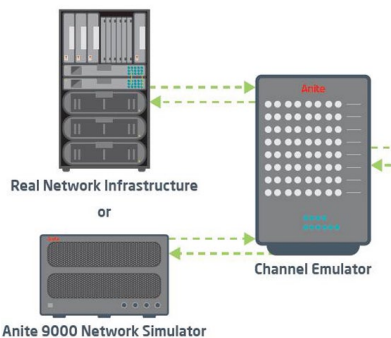

Anite has introduced simulated network support to its Virtual Drive Testing Toolset (VDT Toolset), enabling users to cost-effectively benchmark mobile devices in a controlled laboratory environment. VDT Toolset accelerates product rollouts and quality assurance testing by faithfully reproducing real network conditions in the laboratory. The solution offers the industry's most realistic RF and network simulations, which enables mobile operators and device manufacturers to perform a larger portion of device testing in the laboratory compared to in the field. This approach leads to significant cost-savings in both the development and deployment phases. The virtual drive test solution uses network signalling and RF propagation log data, captured in the field using drive test tools, to recreate a realistic mobile device performance testing environment in the laboratory. It leverages a wide range of Anite IP and products including the Propsim F32 Channel Emulator to create a highly innovative field-to-lab solution for cost-effective benchmarking of mobile devices.

**Anite**  
[www.anite.com](http://www.anite.com)

## Superior quality PCB to ensure your next project's success

As a leading PCB manufacturer and assembler based in China, we are committed to providing high precision PCBs and assembly services to empower you to create great performance products.

First Order **Save 15%**  
 up to \$200 OFF  
 discount code **PCBEE**

**PCBCART**

**WWW.PCBCART.COM**  
 sales@pcbcart.com



# MEMS design for better audio

By Andreas Kopetz

**M**ultiple generations of mobile phone technology have amazed consumers with rapid improvements in the resolution and image capture capabilities of the camera element. This emphasis on imaging technology has made the phone a replacement for hundreds of millions of stand-alone cameras.

In fact, the success of image recording on mobile platforms calls attention to a less visible but equally important element in a consumer's multimedia experience, the audio quality. This is defined by the quality of MEMS Microphones being used.

Throughout the relatively short history of camera-equipped smart phones, audio quality has not improved at the same rate as video quality. One reason for this was the absence of consumer demand. Quite simply, when you are making a voice call, a good microphone primarily benefits the receiver of the call and not the owner of the phone. This makes it difficult to market a good microphone to the buyer of the smartphone.

Microphones in smartphones today do more than capture voice for transmission. They also work as audio sensors in a very low power mode to support voice activation and control. And they provide high quality audio when the phone is used for video recording. Video recording mode especially drives microphone requirements toward higher acoustic performance. It can be very frustrating when an ultra-HD resolution smartphone video is paired with a low-quality audio recording.

Since the smartphone owner directly hears the performance of the microphone when they play back video, microphone quality can be a differentiator. If the audio is poor it may ruin the recording, even if it is in 4K video resolution.

## Acoustic overload point

The popularity of video recording (and sharing) places a greater priority on a microphone's acoustic overload point or AOP. Beside the well-known Signal to Noise Ratio (SNR), the AOP is the most important quality indicator for a microphone.

AOP defines the sound pressure level (SPL) at which the microphone reaches a total harmonic distortion (THD) of 10 percent. As a measurable characteristic, AOP is a good start in evaluating how well a microphone performs at high sound pressure levels, including high noise environments such as concerts and night clubs. In some usage scenarios, even wind noise can

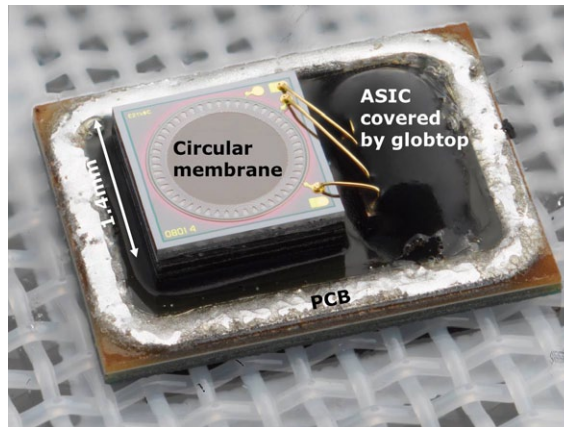

Fig. 1: The typical microphone design combines a MEMS membrane and an ASIC.

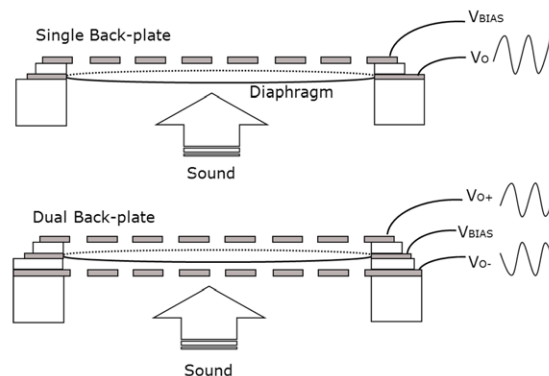

Fig. 2: MEMS microphone capacitive sensor principles: A) Single back-plate and B) Dual back-plate.

cause a microphone to reach its AOP.

In the past, phone manufacturers used 120dB SPL as a baseline AOP level for most microphones. The AOP requirement recently went up to 130 dB SPL and higher. The additional 10 dB results in superior acoustic performance for the end user even in loud concert environments. In addition, higher robustness against wind noise is achieved. Audio algorithms on smartphone level can better process the audio signals without the occurrence of artifacts.

## Micro machines at work

Smartphone microphones are MEMS (Micro Electro-Mechanical Systems) devices fabricated in high volume using semiconductor production processes. The typical design combines a MEMS sensor and an ASIC – see figure 1. The sensor includes a membrane that moves as a result of acoustic pressure, creating an electrical signal that is amplified for analog microphones or processed by the ADC for digital microphones in the ASIC.

Infineon enables high SPL microphones with chipsets that it sells to microphone manufacturers. The solution consists of the MEMS microphone element and an ASIC with analog or digital output. The MEMS microphone, which converts the audio

to an electrical signal, is basically a DC biased capacitor, where movement of a membrane (or diaphragm) caused by audio pressure changes the voltage over a capacitor plate or plates – see figure 2.

The main challenge of handling the pressure level of loud sounds is the large mechanical movement of the membrane which will cause distortion when the membrane is displaced to its extremes. The second challenge is to design the ASIC to handle the large signal that the MEMS element generates.

One way to make a high SPL microphone is to reduce the sensitivity of the microphone by making the membrane stiffer or by reducing the bias voltage. This would reduce movement of the membrane and thus make the generated signal lower. However this also reduces another key parameter, the Signal-to-Noise Ratio (SNR), accordingly. A high SNR is important in many use-cases and describes the margin between the microphone's own noise, which should be as low as possible, and its sensitivity, which should be as high as possible.

## The sandwich effect

Another approach is to implement a MEMS element which places the moving membrane between two capacitor plates as



## MEMS TECHNOLOGIES & ENVIRONMENTAL SENSORS

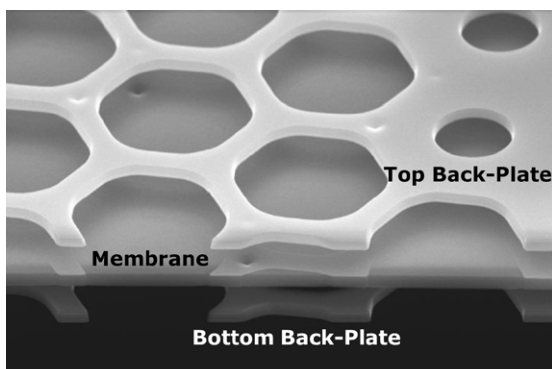

Fig. 3: Infineon's dual back-plate MEMS design for high AOP microphones.

shown in figure 3. This produces a differential (compared to single-ended) output, which has several advantages. A dual back-plate MEMS microphone minimizes distortion due to its symmetrical construction. The same principle is used for high end studio condenser microphones.

A differential element is more readily managed through the audio processing chain (pre-amp, ADC, etc.), which potentially reduces power requirements for the ASIC. It also reduces RF

interference, resulting in fewer signal processing steps.

A dual back-plate device is more robust against wind noise due to the fact that higher AOP Manufacturers of single back-plate devices typically use a filter to eliminate low frequency wind noise, with subsequent impact on audio quality. This filter removes bass, which is particularly important in recording music. After all, it really is all about the bass.

A result of the above is that a dual back-plate device shows a much more linear behavior until it reaches the AOP. Compared to conventional single ended microphones the SPL where audible distortion begins (2 percent) is pushed out by approximately 10 dB. This has significant impact on the quality of the audio signal as shown on the graph of figure 4.

Infineon-based high SPL microphones use a dual back-plate design. This achieves a very high AOP while matching or exceeding the SNR of alternatives in the market today. Audio testing has shown that with excellent audio playback and listening conditions, THD greater than 2 percent is noticeable.

Thus, achieving an AOP greater than the current minimum industry level of 130 dB SPL with less than 2 percent THD is significant.

Infineon commissioned a study by an independent institute to assess microphone performance according to the latest ITU-T recommendation utilizing POLQA (Perceptual Objective Listening Quality Analysis). The results confirm the findings with the subjective listening test box and demonstrate the outstanding performance of microphones based on Infineon's dual back-plate MEMS Technology. There are many elements that affect the final performance of the silicon microphones in a smartphone, including the design of the audio processing chain and the overall microphone array. Multiple variables also affect the overall power consumption of the microphone array, though the reduction of signal-processing complexity made possible with a dual-plate design can be an advantage.

In the end, the best starting point for design of the microphone path is a listening test. Available test boxes pictured in figure 5 can be used to compare low and high AOP microphone elements and provide a baseline for development.

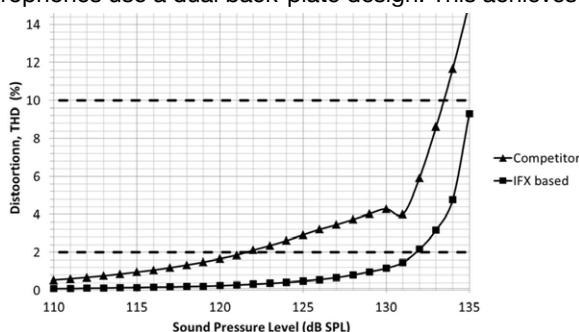

Fig. 4: Measured THD on microphones from a major smartphone tear-down.

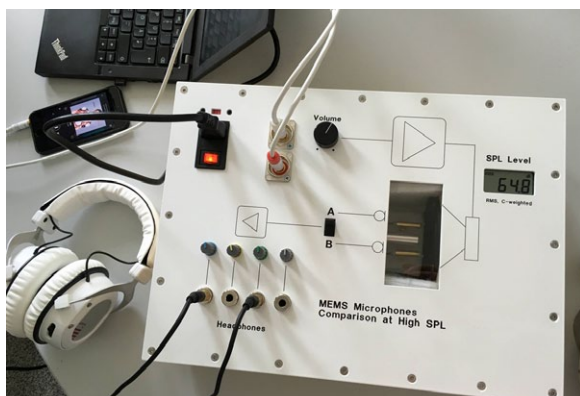

Fig. 5: Portable live demonstrator of high and low AOP microphones.

# PICO

## Surface Mount (and Plug In) Transformers and Inductors

See Pico's full Catalog immediately  
[www.picoelectronics.com](http://www.picoelectronics.com)

Low Profile from  
**4,5mm ht.**



### Audio Transformers

Impedance Levels 10 ohms to 250k ohms, Power Levels to 3 Watts, Frequency Response  $\pm 3\text{dB}$  20Hz to 250Hz. All units manufactured and tested to MIL-PRF-27. QPL Units available.

### Power & EMI Inductors

Ideal for Noise, Spike and Power Filtering Applications in Power Supplies, DC-DC Converters and Switching Regulators

### Pulse Transformers

10 Nanoseconds to 100 Microseconds. ET Rating to 150 Volt Microsecond, Manufactured and tested to MIL-PRF-21038.

### Multiplex Data Bus Pulse Transformers

Plug-In units meet the requirements of QPL-MIL-PRF 21038/27. Surface units are electrical equivalents of QPL-MIL-PRF 21038/27.

### DC-DC Converter Transformers

Input voltages of 5V, 12V, 24V And 48V. Standard Output Voltages to 300V (Special voltages can be supplied). Can be used as self saturating or linear switching applications. All units manufactured and tested to MIL-PRF-27.

### 400Hz/800Hz Power Transformers

0.4 Watts to 150 Watts. Secondary Voltages 5V to 300V. Units manufactured to MIL-PRF-27 Grade 5, Class S (Class V, 155°C available).

Delivery-Stock to one week  
for sample quantities



## PICO Electronics, Inc.

143 Sparks Ave. Pelham, N.Y. 10803  
E Mail: [info@picoelectronics.com](mailto:info@picoelectronics.com)  
[www.picoelectronics.com](http://www.picoelectronics.com)

### Pico Representatives

Germany  
ELBV/Electronische Bauelemente Vertrieb  
E mail: [info@elbv.de](mailto:info@elbv.de)

Phone: 0049 (0)89 4602852  
Fax: 0049 (0)89 46205442

England

Ginsbury Electronics Ltd.  
E-mail: [rbennett@ginsbury.co.uk](mailto:rbennett@ginsbury.co.uk)  
Phone: 0044 1634 298900  
Fax: 0044 1634 290904

# Tips for MEMS mechanical testing

By Julien Happich

**A** provider of scientific instruments for the mechanical testing and robotic handling of microscopic samples, Swiss company FemtoTools AG is taking its know-how to MEMS R&D labs.

In a recent presentation, the company is considering optical and electrical testing scenarios versus the mechanical testing of MEMS for which it has developed a MEMS Probe station, the FT-MPS02.

The wafer-level MEMS testing instrument offers direct mechanical and electrical testing of the MEMS' characteristics, a more complete solution than today's most common alternatives such as electrical response measurement or optical vibration analysis, according to Femtotools.

In his brochure, the company's CEO Dr. Felix Beyeler highlights that most standard instrumentation used for testing MEMS has been designed for semiconductors and is optimized for electrical testing only, which means the mechanical properties of the MEMS are typically only measured at a late stage in the R&D process in final tests.

Yet, he explains, only true mechanical testing with a direct probe contact and concurrent electrical testing or stimulation allows researchers to precisely characterize the relationship between a MEMS' electrical signals and mechanical properties, with force-deflection-time data and without having to make any mathematical assumptions.

It also allows researchers to validate or improve their models, optimize their processes and detect problems early, at wafer level to select good dies only for further packaging.

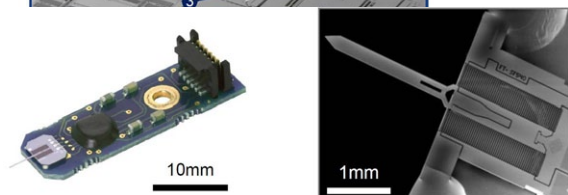
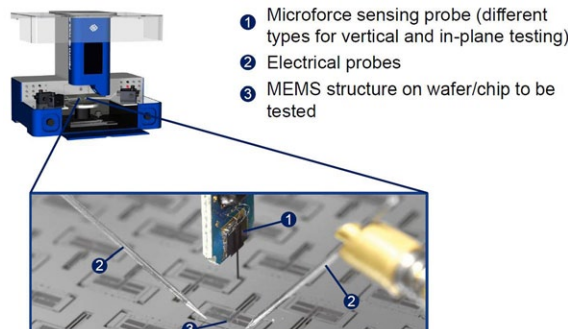

In some cases, the tool could also be used to refine material model libraries in CAD tools relying on Finite Element Analysis.

With a force resolution down to 5nN at the tip of its 50um by 50um silicon probe (optionally, the tip can be furnished by a sharp tungsten probe with a tip radius smaller than 2um), the MEMS probe station can characterize most MEMS sensors and actuators (which can create forces in the Nanonewton to Millinewton range). On unpackaged wafers and chips, the unit can measure sensor output signal versus applied deflection/load,

actuation force versus driving signal, actuation deflection versus driving signal. It can directly measure many other parameters that optical or electrical testing would miss or would have to derive from models, such as stiffness, linearity, elastic/plastic deformation, hysteresis, stiction, over- and underetch, adhesion force, breaking force.

The CEO also pitches the MEMS probe stations against atomic force microscopes (AFM) which are really optimized for surface metrology, hence suffering geometrical limitations due to cantilever geometry but also lacking the combined mechanical and electrical testing capability of the FT-MPS02.

The presentation then reviews several testing examples, among them, for a cantilever-type piezoresistive sensor, characterized with a vertical bending test.

One interesting aspect of the new instrument is that it can perform direct cantilever calibration on the wafer without the need for device packaging, highlighting property distribution of stiffness and output voltage at

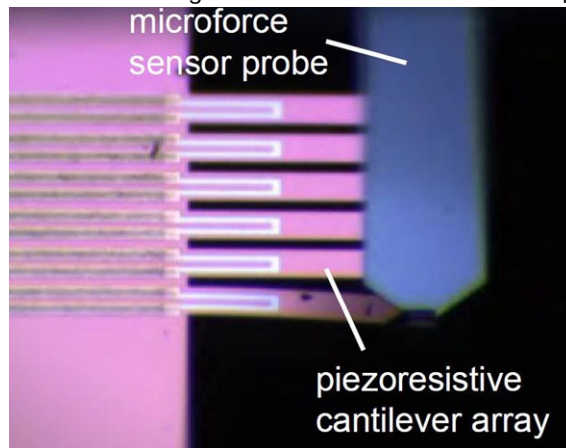

wafer-level, ultimately creating a wafer map and providing a yield rate evaluation. This, Beyeler concludes, improves the efficiency of the MEMS R&D process in small labs, from design houses to academia.

	Electrical Response Measurement	Optical Vibration Analysis	Probe-Based Mechanical Testing
Stiffness	⚡	⚡	➡
Fracture strength	⊘	⊘	➡
Resonance frequency	➡	➡	⚡
Q-factor	➡	➡	⊘
Actuation range	⚡	➡	➡
Actuation force	⊘	⊘	➡

➡ Direct      ⚡ Indirect      ⊘ Typically not possible

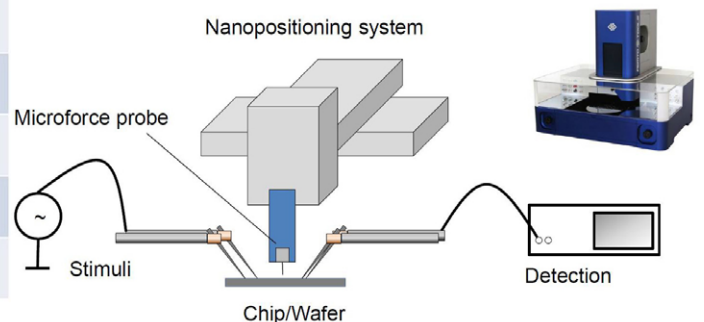



## Omron's plan to cover Earth with IoTs

By R. Colin Johnson

A few years ago Hewlett Packard had the idea of covering the world with sensors to create a central nervous system for the Earth. Now Omron (Kyoto, Japan) has picked up the ball and invented the technologies to make that dream a reality in its description of new sensors and the infrastructure to tie them into a coherent whole at the Trillion Sensors Summit (TSensors 2015) in Celebration, Fla.

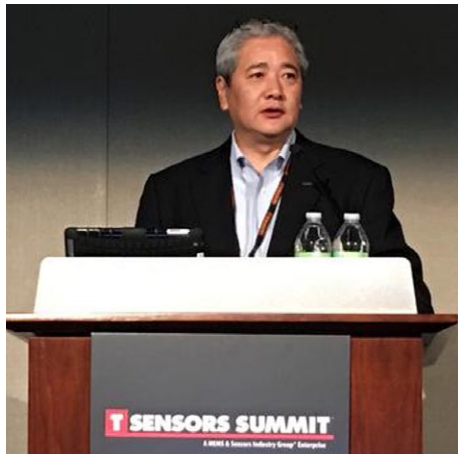

Yoshio Sekiguchi, senior general manager of Micro Devices at Omron Corporation headquarters speaks at the TSensors Summit 2015. (Source: EE Times/R. Colin Johnson)

Most buildings in Japan—even skyscrapers—have elaborate earthquake protection measures. Besides extra steel reinforcement inside concrete, some even go to the extreme of mounting their foundations on gigantic spring-like structures to allow the foundation to remain intact even with extreme swaying that would cause most buildings to collapse.

“Throughout Japan we have 4,377 seismic sensors already, but that is not nearly enough,” Sekiguchi said. “What we need are much smaller, higher accuracy, lower cost systems to expand the network.”

As mentioned, Omron already has three million earthquake detectors in gas meters in Japan, but now they are moving beyond the outdated moving ball technology. To

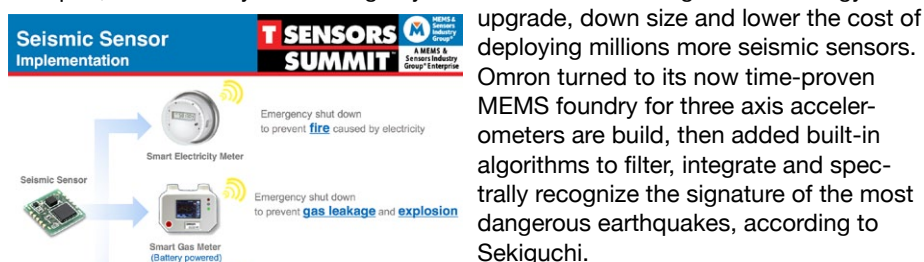

Downsized MEMS accelerometer with added wireless connectivity so that both gas and electricity can be cut off to damaged households, plus emergency responders can quickly ascertain where the most damage was done and thus where to send rescue operations first. (Source: Omron)

It all started before even the mass-market popularity of micro-electro-mechanical system (MEMS) sensors, when Omron won the contract to install three million ball-in-tube accelerometers inside the gas meters around the most earthquake prone areas of Japan. The idea was to sense the severity of their almost daily seismic activity and shut down the gas to homes that may have been damaged enough to potentially have gas leaks, thus averting what are called secondary disasters after earthquakes—in this case gas fires and explosions.

“In Japan we have many earthquakes,” Yoshi Sekiguchi, senior general manager of Micro Devices at Omron Corporation headquarters told the attendees in his presentation at (TSensors 2015). “However, the secondary disasters, such as tsunami’s and fires, are often more serious than the original.”

Omron turned to its now time-proven MEMS foundry for three axis accelerometers are build, then added built-in algorithms to filter, integrate and spectrally recognize the signature of the most dangerous earthquakes, according to Sekiguchi.

Omron’s proposal, besides upgrading the existing ball-based gas meter sensors, is to also build the same platform—with slight modifications, into electric meters—to shut off electricity to prevent electrical fires, plus provide battery powered backup monitoring to continue monitoring tremors in order to maintain situational awareness of all disaster aftermaths.

As the ultimate solution to a central nervous system for mother Earth, Omron has also created a seismic monitor that also tracks temperature, humidity, pres-



## DC-DC CONVERTERS

**NEW!**  
HIGH INPUT VOLTAGES  
UP TO 900 VDC.

### DC-1 Series

- 120-370 VDC input voltage range
- 5-300 VDC regulated isolated outputs
- Up to 300 watts output power
- 4.5" X 2.5" X 0.50" encapsulated package

### DC-3 Series

- 300-900 VDC input voltage range
- 3.3 -300 VDC regulated isolated outputs
- Up to 50 watts, single and dual outputs
- Thru hole and terminal strip models

### HiQP Series

- 125-475 VDC input voltage range
- 24-200 VDC regulated isolated outputs
- Up to 50 watts output power
- 2.50" X 1.55" X 0.50" encapsulated package

ALL MODELS AVAILABLE WITH  
EXPANDED OPERATING TEMPERATURES  
SELECTED MILITARY SCREENING  
CUSTOM DESIGNS

For full characteristics of these and the entire PICO product line, see PICO's Full line catalog at

[www.picoelectronics.com](http://www.picoelectronics.com)

**PICO** ELECTRONICS, Inc.

#### Pico Representatives

Germany  
ELBV/Electroniche Bauelemente Vertrieb  
E-mail: [info@elbv.de](mailto:info@elbv.de)  
Phone: 0049 89 4602852  
Fax: 0049 89 46205442

England  
Ginsbury Electronics Ltd.  
E-mail: [rbennett@ginsbury.co.uk](mailto:rbennett@ginsbury.co.uk)  
Phone: 0044 1634 298900  
Fax: 0044 1634 290904

## Ultra Low Frequency Acceleration Sensor

**T SENSORS SUMMIT**  
A MEMS & Sensors Industry Group Enterprise



Omron has developed a low-cost wireless ultra-low frequency seismic sensor to distribute throughout sections of Japan to give immediate tactical information about earthquakes worldwide using batteries that last 15 years. The company says it could cover the entire Earth with 2.4 billion units. (Source: Omron)

sure, light, ultraviolet (UV) and noise in a single unit with a 15 year battery lifetime. Omron estimates that the entire populated areas of the Earth could be covered with these universal detectors with just 2.4 billion sensors (a windfall for Omron for sure).

With such a network of sensors, Omron estimates that it could not only monitor, but anticipate natural disasters in enough time to warn citizens to flee to higher ground (for tsunamis), to head for shelters (for earthquakes) and to reduce the most devastating effects of natural disasters, namely buildings collapsing, tsunami's and widespread out-of-control fires.

In particular, image the different results in Fukushima, if the reactors had already gone into shutdown mode and all the critical valves had already been shut long before the tsunami hit there. "Not only could people be warned about where safe

## Autonomous Sensing module

**T SENSORS SUMMIT**  
A MEMS & Sensors Industry Group Enterprise



Omron has also developed a multipurpose version that measures not only seismic vibration, but temperature, humidity, pressure, light, ultra-violet (UV), and noise for worldwide situational awareness that could also cover the globe like a nervous system for the Earth. (Source: Omron)

## Processing of IoT data will move closer to "the edge"

**T SENSORS SUMMIT**  
A MEMS & Sensors Industry Group Enterprise

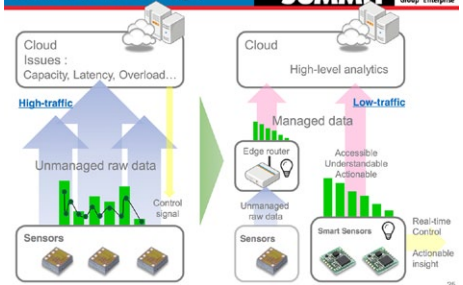

The company has designed edge-routers that digest the raw data from its sensors sending only managed low-frequency traffic up to the cloud where high-level analytics can keep track of every spot on the Earth. (Source: Omron)

places are to go before a disaster, but damage estimates could be immediately made in real time, accessing which areas are in most need, reduce the risk of secondary disasters and identify to people where to go in the aftermath, such as the nearest hospital that is still operating," Sekiguchi said.

Currently, Omron is perfecting the infrastructure by which raw sensor data can be concentrated into only the most important parts, using local smart routers, which can then send summaries to managers and the cloud where sophisticated high-level analytics can be run on high-performance computers (HPCs).

Hopefully these analytics will be able to use deep learning to get better and better at anticipating disasters of all types—from earthquakes to volcanos erupting, making all the people of the Earth a little safer.

## Signal conditioner preps data from consumer pressure and thermopile sensors

IDT's ZSSC3224 is a 24-bit sensor signal conditioner (SSC) IC designed for energy-efficient designs with consumer barometric pressure and thermopile sensors. The part is one of the first released by the former ZMDI (Dresden, Germany) since its acquisition by IDT in 2015. The device has an integrated 26-bit digital signal processor (DSP) for linearisation and calibration functions, for high-resolution



consumer, industrial, white goods and medical applications, as well as phones and tablets, and joins a family of SSCs designed for high-end sensor modules: it delivers high-accuracy amplification and a 24-bit precision full-featured analogue-to-digital converter. The ZSSC3224 is suitable for high-precision measurement systems, including barometric altitude measurement for portable navigation or emergency call systems; altitude measurement for car navigation; pressure measurements inside hard discs; and weather forecasting equipment. The device—available in die and wafer form—can also adapt thermopile sensors to enable contactless temperature measurements of objects or

human body temperature. Michael Georgi, product marketing manager, adds, "The device is designed for use with resistive pressure sensors as well as absolute voltage sensors such as thermopiles. A stacked die assembly, combined with a dedicated MEMS sensor element, can provide the lowest form factor on the market for MEMS-based sensors." Targeting battery-driven, low-power devices, features such as 1 mA typical overall current consumption, 20 nA typical sleep mode current, and a 1.68V to 3.6V power supply range combine with an intelligent power-save scheme to help ensure the lowest overall current consumption. The device also offers internal filter options for low noise output signals and intelligent alarm and interrupt capabilities. The ZSSC3224 eliminates the need for an external buffer capacitor and it provides power supply rejection ratio (PSRR) of up to 90 dB at 2V, making it attractive for applications in harsh environments. Digital compensation of signal offset, sensitivity, temperature and non-linearity is accomplished via an internal correction algorithm with coefficients stored on-chip in a reliable, nonvolatile, programmable memory. Other features include: Quadratic form factor, optimised for stacked die assembly; operating temperature range: -40°C to 85°C; programming via software provided in the evaluation kit; accuracy better than ±0.10% full-scale output.

**IDT**  
[www.idt.com](http://www.idt.com)



## Inclination and tilt sensors targets heavy industry

MEMSIC Inc.'s MTLT series of inclination and tilt sensors are appropriate for a wide range of static and dynamic applications in construction and industrial markets such as boom tilt monitoring, bucket loader roll back protection, PV/CSP solar tracking systems and others. Samples of the first three family members in MTLT series, the MTLT110S-R, MTLT105S-R and MTLT105D-R are currently available for evaluation. All three products of the series are IP67 rated inclinometers with an integrated RS-232 interface and flying lead cable operating from a 9 V to 32 V single supply.



The MTLT105S and MTLT110S are designed for applications needing less than 0.5 degree and less than 1.0 degree accuracy, respectively, over the full operating temperature range. The MTLT sensors also include programmable tilt alarms for tilt safety applications. The alarm can be programmed to be triggered to activate when the tilt exceeds a specified threshold. The tilt alarm can also be used to lock out controls or trigger an alarm or warning light. It is an all-in-one tilt safety solution eliminating the need for an external microprocessor to interpret tilt angles. The MTLT family achieves the best price and performance by utilizing Micro Electro-Mechanical System (MEMS) sensors, extensive over temperature calibration, and MEMSIC's SmartSensing technology providing users with unmatched sensor fusion and performance in critical motion sensing applications. Each unit is fully calibrated over temperature providing confidence in safety applications.

**MEMSIC**  
[www.memsic.com](http://www.memsic.com)

## Ultrasound proximity software replaces hardware-based sensors

Elliptic Labs has launched a software-based ultrasound proximity sensing solution that relies on the smartphones' speaker and microphone to replace today's optical proximity sensors. Beauty, as the ultrasonic software is called, allows for more aesthetically pleasing designs since it removes the need for optical proximity sensors, which themselves typically require one rectangular black shape or two small holes on the screen. Enabling always-on gesture detection, the solution also frees up physical space inside mobile devices. "It works very similar to



how bats use echolocation to navigate. The Ultrasound signals are sent through the air from a smartphone's current earpiece and bounce against one's head and are recorded by the smartphone's microphone. In this way, Elliptic Labs' software engine converts the ultrasound signals into command actions and for the Beauty product case -to turn off/on the screen. Our Beauty product only requires one earpiece and one microphone currently available in all smartphones", explained Elliptic Labs' CEO, Laila Danielsen. The company's Beauty product maps its proximity readings to standard sensor service in Android, thus requiring no additional user interface. But detection range goes up to 2m, enabling high-resolution touchless gestures near, far, and all around the sides of a device screen at 180 degrees. The software also comes with an extended library of gestures and application samples, including scrolling and multi-layered interaction.

how bats use echolocation to navigate. The Ultrasound signals are sent through the air from a smartphone's current earpiece and bounce against one's head and are recorded by the smartphone's microphone. In this way, Elliptic Labs' software engine converts the ultrasound signals into command actions and for the Beauty product case -to turn off/on the screen. Our Beauty product only requires one earpiece and one microphone currently available in all smartphones", explained Elliptic Labs' CEO, Laila Danielsen. The company's Beauty product maps its proximity readings to standard sensor service in Android, thus requiring no additional user interface. But detection range goes up to 2m, enabling high-resolution touchless gestures near, far, and all around the sides of a device screen at 180 degrees. The software also comes with an extended library of gestures and application samples, including scrolling and multi-layered interaction.

**Elliptic Labs**  
[www.ellipticlabs.com](http://www.ellipticlabs.com)

## ST offers infrared time-of-flight sensor

STMicroelectronics has launched a time-of-flight ranging sensor for autofocus, proximity sensing and object detection in robotics, drones and IoT applications. The company claims the VL53L0 is the smallest time-of-flight (ToF) module in the world and the first to use a 940nm infrared light source. One result is that the VL53L0 can range faster, over longer distances, and more accurately than previous members of ST's FlightSense family. The unit integrates a 940nm wavelength VCSEL light source and a single photon avalanche diode (SPAD) detector as well as microcontroller to implement digital detection algorithms. The unit measures 4.4mm by 2.4mm by 1mm. It can perform a measurement operation in typically less than 30ms at distances of greater than 2m. The VL53L0 module includes an I2C interface and comes with API drivers.

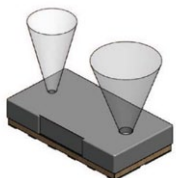

**STMicroelectronics**  
[www.st.com](http://www.st.com)

# sonitron<sup>®</sup>

Piezo audio components







B buzzers Transducers Alarms  
Sirens Piezo Speakers Amplifiers

[www.sonitron.be](http://www.sonitron.be)

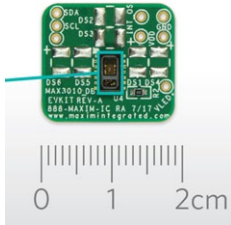

## Pulse oximeter/heart rate sensor module for wrist-band designs

With the MAX30102 pulse oximeter and heart rate integrated sensor module, Maxim Integrated provides an ultra-low power solution for wearable health and fitness applications. It is a complete system solution to save space and ease the design-in process for mobile and wearable devices. MAX30102 integrates red and IR LEDs to modulate LED pulses for oxygen saturation (SpO2) and heart rate measurements. It operates on a single 1.8V power supply and a separate 5V power supply for the internal LEDs. The device maintains a very small solution size without sacrificing optical or electrical performance; it integrates internal LEDs, photodetectors, optical elements, and low-noise electronics with ambient light rejection. An evaluation platform with the integrated module and an accelerometer provides a solution for designers to quickly evaluate the module. In a 14-pin optical module 5.6 x 3.3 x 1.55 mm, and specified over the -40 to +85C temperature range, pricing starts at \$4.13 (1000). An evaluation board is available.



**Maxim Integrated**  
<http://bit.ly/MAX30102>

## Power monitor IC keeps real-time eye on multiple loads

Microchip Technology's MCP39F511N supports widely-used standard power calculations and event monitoring of two electrical loads; the device is applied in system design and reduces system cost of power-monitoring wall outlets and smart plugs, power strips, AC/DC power supplies and power distribution applications. The IC includes three analogue to digital



Dual-Channel Power Monitoring IC

converters (ADCs) for voltage and two current load measurements, a 16-bit calculation engine, EEPROM and a flexible 2-wire interface. Microchip says that the dual-channel power-monitoring IC facilitates application design as it reduces firmware development and the number of ICs required for power monitoring of multiple loads. An integrated low-drift voltage reference in addition to the 94.5 dB of SINAD performance on each current measurement channel allows the MCP39F511N to monitor two current loads with 0.5% error across a 4000:1 dynamic range. The ability to measure active, reactive and apparent power, active and reactive energy accumulation, RMS current and RMS voltage, line frequency, and power factor combined with advanced, integrated features allows system designers of high-performance devices to reduce bill of materials and reduce time-to-market. The MCP39F511N is supported by the MCP39F511N Power Monitor Demonstration Board (Part no. ADM00706), which is available now for \$200. In a 28-lead, 5x5 mm QFN package the IC is priced at \$1.82 (5,000).

**Microchip**  
[www.microchip.com](http://www.microchip.com)

## Ambiq's Apollo sub-threshold 32-bit MCU is yours to evaluate

This month Ambiq Micro is giving away five of its 'Apollo EVB' evaluation boards, worth \$249 each for EETimes Europe's readers to assess the capabilities of its cutting-edge Apollo sub-threshold microcontroller. The new suite of Apollo MCUs is based on the 32-bit ARM Cortex-M4 floating point microcontroller and redefines 'low power' with energy consumption that is typically five to ten times lower than that of MCUs of comparable performance (thanks to Ambiq's patented Subthreshold Power Optimized Technology platform). On-board user interfaces include three user pushbuttons, an MCU reset pushbutton, four user LEDs, and a serial-wire-debug activity LED. The baseboard also includes four female expansion card connectors in individual 2x14 pin arrays, which also function as header test points. The baseboard also features an additional right-angle 2x14 header connector for attaching smaller expansion cards. The evaluation board integrates an on-board hardware debugger together with a complete SDK. In addition, the system also comes with FreeRTOS, all the necessary hardware drivers, plus a wide selection of code examples to enable quick and effective hardware and software evaluation, development, debug and prototyping.

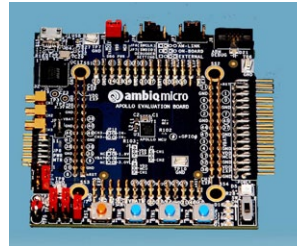

**Check the reader offer online at**  
[www.electronics-eetimes.com](http://www.electronics-eetimes.com)

## VisualSim memory modelling library boosts algorithm exploration

Mirabilis Design has released the VisualSim Memory modelling library, containing all current and prior versions of DDR, LPDDR, HBM, SRAM, JEDEC-compliant memory controller and a generic memory controller. System designers and architects can use this library to develop new memory sub-systems, explore new standards and algorithms, and optimize the memory access for their target application. The solution has been used to conduct trade-off between different speed/variations of DRAM, performance vs. power, and memory bandwidth efficiency. VisualSim Memory can be used with VisualSim resource, behaviour and cycle-accurate modelling libraries to construct models, simulate and analyze the complete system or SoC. This library is used to validate proposal, conduct trade-off decisions, timing, throughput, arbitration algorithm, power consumption analysis, and study systems behaviour with different configuration (single vs. dual channels, clock speed variations, addressing schemes, and controller algorithms).

**Mirabilis Design**  
[www.mirabilisdesign.com](http://www.mirabilisdesign.com)

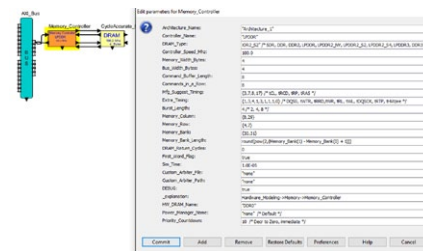



### 3D Plus promises universal space-grade colour CMOS camera module

The CNES (French Space Agency) and 3D PLUS partner to develop a colour camera fully qualified for space applications, and due to embark on NASA's Mars 2020. This development is a follow-up to a first R&D study that has been conducted between the two partners in 2015. It will be held over 14 months, and flight models are expected to be available beginning of 2017. The camera module will feature a 4Mpixel colour CMOS sensor, of high resolution-enough to provide good data while staying within a reasonable communication budget for power-constrained space applications. 3D Plus will receive the space qualified CMOS sensor from the

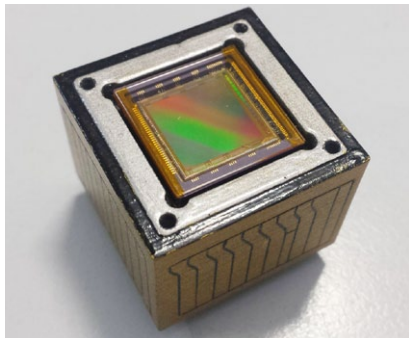

CNES (who will perform thermal cycling from -55 to +125°C, radiation exposure and vacuum tests) and integrate it with an FPGA, memory, power supply and custom circuitry, all previously space qualified, into its signature cubic form factor. The whole module will then go through another space qualification process, which the company admits represents the longest part of the development for such products. But it hopes to offer the final module off-the-shelf and competitively priced, designed to be universal enough to find its way into other space applications such as for example star trackers on board small satellites. For the Mars 2020 rover mission, the camera module will be installed in the SuperCam scientific instrument developed by Los Alamos Laboratory and IRAP (CNRS / Université Paul Sabatier, Toulouse, France). It will provide imaging, chemical composition analysis and mineralogy in rocks and regolith from a distance. The module will also be deployed on-board EYE-SAT, a nano-satellite developed by the CNES for earth and zodiacal light observation.

3D Plus will receive the space qualified CMOS sensor from the

**3D PLUS**  
[www.3d-plus.com](http://www.3d-plus.com)

### Microstepping motor drive ICs with simple command interfacing

Allegro's A5976, A5977 and A5979 have been designed to operate bipolar stepper motors in full-, half-, quarter-, eight-, (A5977) and sixteenth- (A5976/79) step modes; the ICs are complete microstepping motor driver ICs with built-in translators. All have the output drive capability of 40V and  $\pm 2.8A$  and include a



fixed off-time current regulator that has the ability to operate in slow, fast, or mixed-decay modes. This current-decay control scheme results in reduced audible motor noise, increased step accuracy, and reduced power dissipation. The translator is the key to the easy implementation of these devices. Simply inputting one pulse on the STEP input drives the motor one step or microstep (two logic inputs determine if it is a full-, half-, quarter-, eighth- or sixteenth-step resolution). There are no phase sequence tables, high-frequency control lines, or complex interfaces to program. The interface is a good fit for applications where a complex microprocessor is unavailable or overburdened. Internal synchronous rectification control circuitry is provided to improve power dissipation during PWM operation. Internal circuit protection includes OCP (overcurrent protection) thermal shutdown with hysteresis, undervoltage lockout (UVLO), and crossover-current protection. An open-drain FAULT output is included in the A5976 for improved diagnostic reporting. Special power-up sequencing is not required. All three devices are supplied in a thin, under 1.2-mm profile, 28-pin TSSOP with exposed thermal pad. Data sheets are at; A5976, A5977 and A5979

**Allegro MicroSystems**  
[www.allegromicro.com](http://www.allegromicro.com)

### Efficient car audio system PSU IC makes 2/3 power saving

Addressing the car audio market for multifunction power supplies, Rohm has developed a system power supply IC



for which it claims lowest-available power consumption. BD49101AEFS-M is based on a high-efficiency DC/DC converter, achieving power consumption reduction of 65%, from 13.3W with

Rohm's conventional products to 4.66W. Less heat generation makes it possible to adopt a surface mount package without requiring an external heat sink, simplifying thermal designs considerably while contributing to greater space savings. Integrating all system power supplies required for car audio systems on a single chip – including for USB with a cable impedance function – contributes to a lighter design load. In DC/DC converters, because efficiency drops when the load current decreases (i.e. during standby), the BD49101AEFS-M integrates a low-current linear regulator dedicated for continuously powering the MCU. During standby operation the IC switches from the DC/DC converter to the linear regulator, reducing quiescent current that flows when the engine is idle to 100  $\mu A$  (typ.). The device comes in a compact surface-mount package with small backside heatsink. This eliminates the need for thermal counter measures and results in 14x less volume compared with conventional products. When charging USB devices it is necessary to compensate for the drop in voltage caused by the cable wiring resistance. Rohm includes a built-in compensation function that maintains the cable end voltage, minimising charging time and ensuring compliance with USB standards. An output terminal is included for notifying the MCU of overcurrent conditions.

**Rohm Semiconductor**  
[www.rohm.com](http://www.rohm.com)

# DESIGN & PRODUCTS

## OEM board supports 4K/UHD HDMI transport over IP

Barco Silex has launched an OEM board for the professional audio-visual market, that enables the transport of HDMI video/audio over IP networks, including high-resolution video up to 4K/UHD over a single 1 Gb Ethernet cable. The built-in hardware compression/decompression (SMPTE 2042 VC-2) combines lossless quality with ultra-low latency. Designed for seamless integration and configuration, the new board supports a wide range of network topologies with multiple sources and displays. The configurability of the board addresses many different setups required in the pro AV market, from the simple point to point transmission up to the multi-channel flexible network or video wall. The video/audio path is processed in real-time within the FPGA fabric while the processor is handling all the control and configuration of the board. Both the FPGA firmware and the CPU software can be easily upgraded.

**Barco Silex**  
[www.barco.com](http://www.barco.com)



## Himax launches 'always on' image sensor

Himax Imaging, Inc. (Tianan, Taiwan) has announced the HM01B0, a QVGA resolution CMOS image sensor that consumes less than 2mW when running at 30 frames per second.

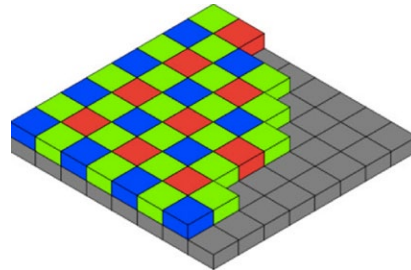

The sensor has lower power modes that go down to 700-micro-watt when operating at QVGA. The unit is intended for 'always on' contextually aware computer vision capabilities such as feature extraction, proximity sensing, gesture

recognition, object tracking and pattern identification. The HM01B0 has a motion detection circuit, an interrupt output pin, and an automatic exposure and gain control loop. The sensor utilizes 3.6µm pixel technology that offers sensitivity of below 1 lux. The sensor's reflowable chip scale package measures less than 5 square millimeters of board area and only three passive components externally. Himax believes its HM01B0 is suitable for mobile devices, augmented and virtual reality applications, IoT and artificial intelligence applications. The HM01B0 will be available in both monochrome and color options. Himax is planning to deliver samples to selected customers in 1Q16.

**Himax Imaging, Inc.**  
[www.himaximaging.com](http://www.himaximaging.com)

## DC:DC LED drivers focus on high power LEDs

Ideal Power has introduced two high power, high efficiency DC:DC converters for domestic, industrial, architectural and automotive LED lighting systems. The 36KC24H and 36KC24W

series of DC:DC LED Drivers are step-down constant current sources designed for driving high power LEDs. They feature high efficiency operation up to 96% and wide input voltage range from 5.5 to 48VDC making them suitable for systems operating from 12V,

24V and 36V at up to loads of 25W. Both models have a high operating temperature, PWM and analogue dimming controls and remote ON/OFF. Typical applications include LED illumination in areas such as decorative, landscape, backlighting, commercial, street, domestic automotive lighting and special control lights. Main features of the LED drivers include, high power output current of 1,000 to 1,200mA, efficiency up to 96%, ultra-wide input and output voltage range, constant current mode, PWM and analog dimming, remote ON/OFF, low ripple and noise, continuous short circuit protection and meet EN55015 without external circuitry. The 36KC24H is a PCB mounting package while the 36KC24W series is connected via output leads offering more flexible mounting options and is waterproof to IP67.

**Ideal Power**  
<http://idealpower.co.uk>

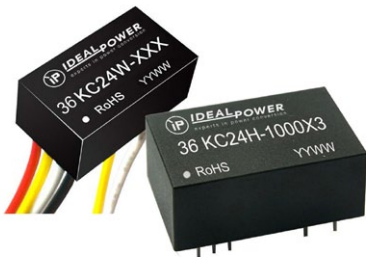

## Power I/O connectors mount directly onto the PCB

HanOnBoard is a connector technology which can replace standard discrete wiring by allowing power I/O connectors to be mounted and connected directly onto the printed circuit board (PCB). With the HanOnBoard concept, Harting's Han connectors are connected to the board via a PCB mounted adapter through which data, signals and

power are distributed. This solution eliminates time-consuming and potentially fault-prone wiring. Because HanOnBoard is compact and weight-saving in use, it offers additional benefits over traditional wiring: printed circuit boards are more resistant to external influences such as shock and vibration compared with discrete wiring, and the total electrical path can be conformally coated to provide enhanced protection. This makes it suitable for use in the harsh environments found in transport, industrial machinery and automation applications. A PCB with HanOnBoard can replace dozens of power cable interconnections, allowing distribution boxes to be made lighter and more compact. It will also help to reduce production costs through streamlined production processes and less material usage. A range of different adaptors and Han contacts covering most of the Han range are available in the HanOnBoard range.

**Harting**  
[www.harting.co.uk/integrated-solutions](http://www.harting.co.uk/integrated-solutions)

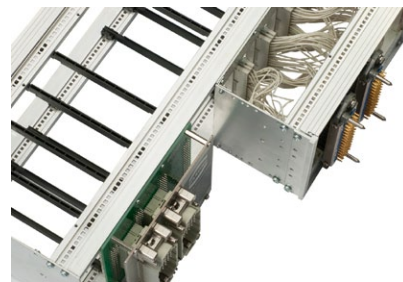



# Maintaining a competitive edge in 2016

By Mike Buffham

**D**ifferentiation and competition between distributors has always been an important characteristic of the industry. However, in 2015 we saw a real widening of the scope of this competition. Not only was this centred on the areas that had characterised 2014 - manufacturing, production, design and volume - but attempts to address new vertical markets moved into the spotlight over the course of 2015. However, as unpredictable market conditions continue into the new year, we expect to see distributors take steps to intelligently consider where to target investment and in which areas to focus their competitive efforts.

As always, one of the key areas of competition between distributors will be on their core offering. But it's no longer a 'nice to have' for a distributor to provide a diverse range of products, rapid delivery, and robust after-support; it is now a basic customer expectation increasingly based on consumer experiences. This means that it is becoming increasingly difficult for distributors to differentiate on their basic offering.

The key areas of competition in terms of businesses' core offerings will therefore be in ensuring it meets customers expectations reliably and consistently, and then in finding new areas of differentiation where distributors can exceed customer expectations. This is not necessarily about providing something completely new, but rather placing a renewed emphasis on product range and availability, delivery methods, technical expertise and availability of supporting content. For example, our own strategy for this year features continued investment in agreements with key suppliers. This means we can expand our range with original and exclusive products, whilst continuing to grow our 370,000 strong Community of engineers, who can provide additional pre and post-sales support to customers.

This extends to an intelligent approach to targeting resources and customers. Understanding customer segments - and what their specific needs are - will enable more efficient targeting of investment in new services, ultimately encouraging greater brand loyalty amongst that user group. For example, we know that a large proportion of our customers are buyers, therefore reliable deliveries remains a top priority; whereas our engineer customers are looking for a distribution partner that can offer first access to the latest and best-in-class products.

Out of this focus on the core business come two other key areas of competition for 2016: provision of data and a focus on the value-add.

In recent years increased competition, globalisation of the electronics supply chain, and stringent government regula-

tions have placed intense pressure on customers to be able to trace the life-journey of the components they are using in the manufacturing process. Common queries relating to traceability include: whether the products have been assembled using defective components or conflict minerals; whether distributors can provide a guarantee that no counterfeit components have entered the supply chain; and whether the process used to assemble the components complied with industry standards.

In reality, there remain questions over whether compliance with industry regulations is the legal responsibility of suppliers or distributors, as in the case of legislation like The Restriction of Hazardous Substances (RoHS) bill. But chain traceability is already crucial to the military and aerospace markets, which electronics distributors are increasingly competing over. Possession of an AS9120 standard certification is a key requirement for enabling business with these organisations and it requires proven ability to trace supply chains.

To give an example from our own business, we're working to provide full traceability by affixing date and lot codes to more than 200,000 SKUs. Coupled with fully automated, bar-coded product labels and dispatch notes on our most popular semi and passive components, these initiatives aim to streamline factory automation and improved stock control such that greater traceability can be provided - helping to gain a competitive edge in new market opportunities within the fast-growing automotive, medical and industrial sectors.

Another area of competition amongst 'traditional' distributors in 2016 will be a real focus on value-add services. Crucially, these will build upon the approaches taken to the core-business, characterised by an intelligent, targeted approach. These will centre on areas where traditional distributors can demonstrate their value to customers over new entrants, often the result of many years of investment.

Look at this from Farnell element14's perspective, customisation is an area that we intend to grow exponentially over the next year. This is both a targeted attempt to assist designers in driving down their time to market, through initiatives such as Custom Pi. Due to strategic acquisitions of AVID and Embest, we possess the unique design and manufacturing capabilities that such a service requires, offering a real value-add to the designer customer segment.

It's important that distributors do not fall into the trap of doing all things for all customers at all times. Through careful re-evaluation of the products and services that distributors compete on, they will be better placed to cultivate a loyal customer base and ensure that they have a solid foundation to their business. Only then will they be in an appropriate position to develop additional services that can offer real value to customers and differentiate their businesses from the competition.



Mike Buffham is Global Director of Semiconductor and Passive at element14 - [www.element14.com](http://www.element14.com)

## PUBLISHER

André Rousselot  
+32 27400053  
andre.rousselot@eetimes.be

## EDITOR-IN-CHIEF

Julien Happich  
+33 169819476  
julien.happich@eetimes.be

## EDITORS

Christoph Hammerschmidt  
+49 8944450209  
chammerschmidt@gmx.net

Peter Clarke  
+44 776 786 55 93  
peter.clarke@eetimes.be

Paul Buckley  
+44 1962866460  
paul@activewords.co.uk

Jean-Pierre Joosting  
+44 7800548133  
jean-pierre.joosting@eetimes.be

## CIRCULATION & FINANCE

Luc Desimpel  
luc.desimpel@eetimes.be

## ADVERTISING PRODUCTION & REPRINTS

Lydia Gijsegom  
lydia.gijsegom@eetimes.be

## ART MANAGER

Jean-Paul Speliers

## ACCOUNTING

Ricardo Pinto Ferreira

## REGIONAL ADVERTISING

### REPRESENTATIVES

Contact information at:  
<http://www.electronics-eetimes.com/en/about/sales-contacts.html>

## ELECTRONIC ENGINEERING TIMES EUROPE

is published 11 times in 2016  
by EUROPEAN BUSINESS PRESS SA

Chaussée de Louvain 533,  
1380 Lasne, Belgium  
Tel: +32-2-740 00 50

Fax: +32-2-740 00 59

email: [info@eetimes.be](mailto:info@eetimes.be)

[www.electronics-eetimes.com](http://www.electronics-eetimes.com)

VAT Registration: BE 461.357.437.

Company Number: 0461357437

RPM: Nivelles.

Volume 18, Issue 1 EE Times P 304128

It is free to qualified engineers and managers  
involved in engineering decisions – see:

<http://www.electronics-eetimes.com/subscribe>

© 2016 E.B.P. SA

All rights reserved. P 304128



## DISTRIBUTION CORNER

### Avnet Memec – Silica to host over 60 demos at Embedded World

With a 250sqm booth on stand 1-370 at Embedded World 2016, in Nuremberg, Avnet Memec - Silica will launch and show a range of innovative solutions, running over



60 demos on seven demo stations. The solution area will showcase demos which address a range of challenges encountered by design engineers, including enabling companies to benefit from the vast opportunities offered by advanced Internet of Things products, systems and technologies. The demo-stations will cover connectivity, FPGAs and SoCs, sensors and signal chain, power, and microcontrollers and microprocessors.

Avnet Memec – Silica  
[www.avnetmemec-silica.com](http://www.avnetmemec-silica.com)

### Future Electronics opens Munich regional headquarters

Electronics components distributor Future Electronics has opened new headquarters for its Central Europe region, in Muenchen, Germany. The move to a new, bigger office complex near the site of the Messe Muenchen exhibition halls provides Future Electronics with space to accommodate its growing workforce. The Central Europe division of Future Electronics, which includes the D/A/CH countries and The Netherlands, is in the middle of an expansion programme as it gears up to support growing numbers of customers and an expanded line-up of suppliers. The increased floor space will allow Future Electronics to accommodate more specialist engineers for fast-growing markets.



Future Electronics  
[www.futureelectronics.com](http://www.futureelectronics.com)

### RS aims for greater own-label brand recognition with “RS Pro”

Distributor RS Components, and Allied Electronics, (Allied), both identities of Electro-components are to make increased use of their “private label” product lines with a new branding, and positioning as a “value” product line. The Value marketing under the RS Pro identity seeks to create an image of items that are keenly-priced but fully specified, tested and warranted to be dependable alternatives to premium brands (that RS also continues to sell). To back the move, RS is to step up its internal testing a certification resources and add a seal of approval marking. RS acknowledges that this is something of a return to the roots of the company.



RS Components and Allied Electronics  
[www.rs-online.com](http://www.rs-online.com)

### Richardson Electronics to distribute Anokiwave’s RF ICs

Richardson Electronics has expanded its portfolio of core ICs for commercial AESAs from Anokiwave, Inc., adding two new devices from the company’s family of X-band AESA core IC solutions for commercial radar and 5G communications markets. Each IC architecture in the family includes an integrated 4-channel beamformer, LNA and PA supporting 4 radiating elements. The ICs feature either a low noise figure or a high input linearity, and they are further divided by dual beam Rx/single beam Tx, or single beam Rx/single beam Tx.

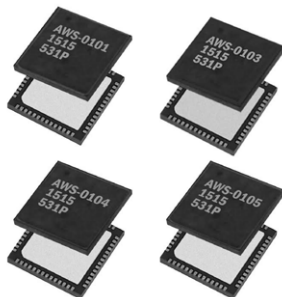

Richardson Electronics  
[www.rellpower.com](http://www.rellpower.com)



# Your Global Link to the Electronics World



## ANALOG

[www.analog-eetimes.com](http://www.analog-eetimes.com)

## WHERE THE WORLD CONNECTS



**Wearables**

**Internet  
of Things**



**Home  
Automation**

[www.smart2zero.com](http://www.smart2zero.com)

[www.smart2zero.com](http://www.smart2zero.com)



**BREAKING  
NEWS**

**Stay informed  
on what's going  
on in the  
electronics industry**

[www.electronics-eetimes.com/newsletters](http://www.electronics-eetimes.com/newsletters)



## LEDLighting

[www.ledlighting-eetimes.com](http://www.ledlighting-eetimes.com)



## MICROWAVE

[www.microwave-eetimes.com/](http://www.microwave-eetimes.com/)



**EET  
Search**

**IoT**

[www.eetsearch.com](http://www.eetsearch.com)





# Infineon's solution for automatic opening systems

Enabling benchmark efficiency for your application



At present, every building utilizes opening systems at numerous positions in and around. These openings are equipped with different systems to manage various actions based on their task.

Infineon offers a full system solution for opening systems, making applications more energy efficient and assisting to secure against unauthorized manipulation of firmware update. Incorporated products are smart sensors, motor controls, supplies and battery management, which help to reduce energy losses in all conditions. Our radar solutions cover a 16 times larger area than common infrared solutions.

## Key highlight products:

- › OptiMOS™ and StrongIRFET™ Power MOSFETs 20 V-300 V – a powerful combination
- › CIPOST™ – integrated motor drive solutions enabling cost efficient designs
- › 600 V CoolMOS™ P6 Power MOSFETs – ease-of-use and superior efficiency for your SMPS application



To learn more about Infineon's system solution please visit:  
[www.infineon.com/automaticopeningsystem](http://www.infineon.com/automaticopeningsystem)







# embeddedworld 2016 show guide

# EE Times europe

Hall 1: Booth 1-510



## MICROCHIP

### MPLAB® Xpress Cloud-based Integrated Development Environment

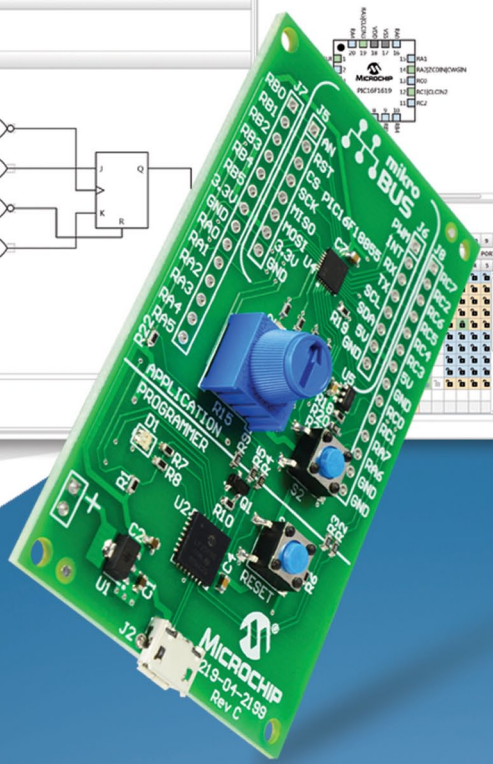
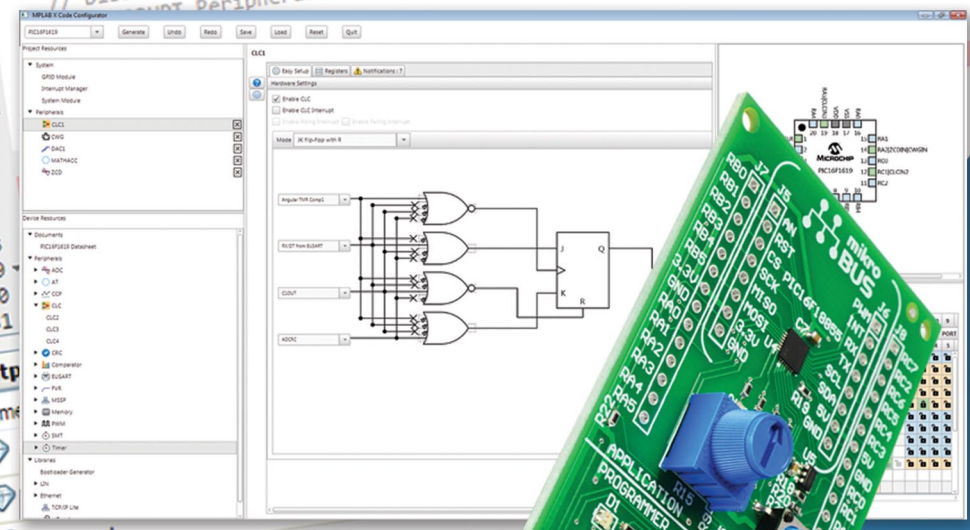
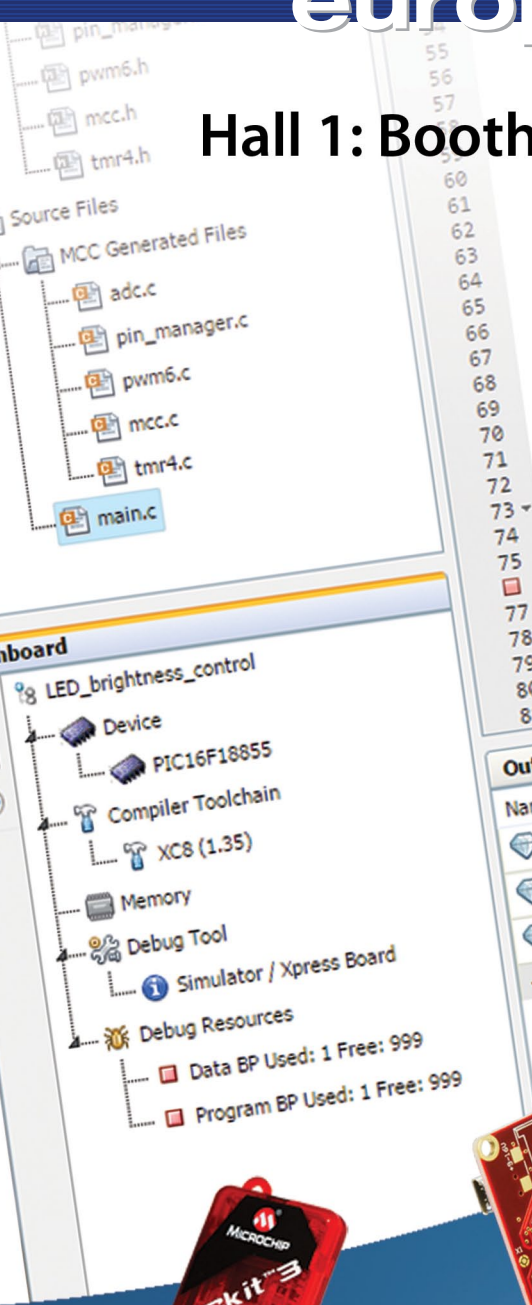

MPLAB® Xpress  
Evaluation Board

Curiosity  
Development Board

PICKit™ 3



# DIGI-KEY

## Most Preferred Distributor

Source: Distributor Evaluation Study, UBM Tech, May 2015

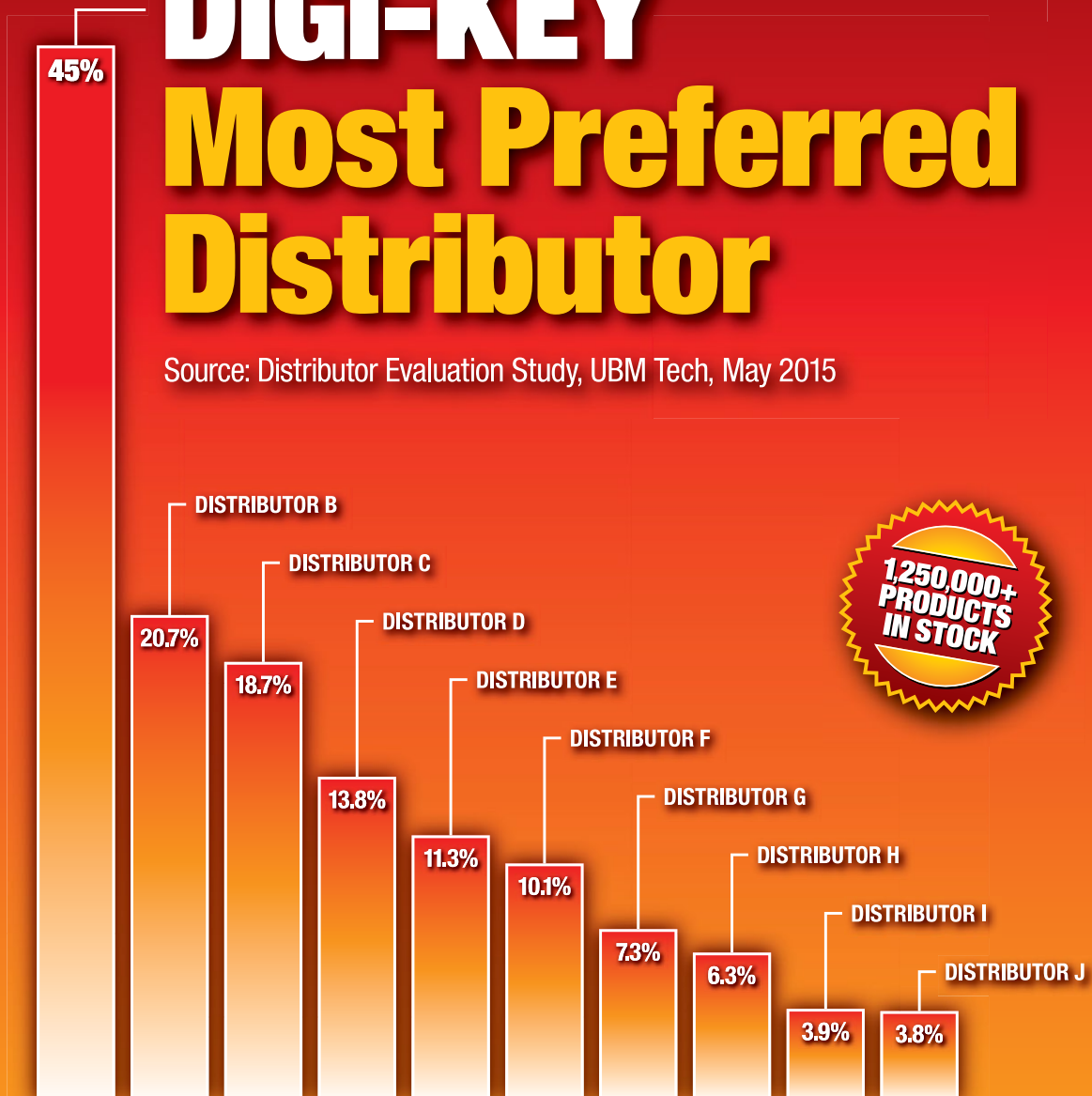

**1,250,000+  
PRODUCTS  
IN STOCK**



FIND CONTACT AND ORDERING  
INFORMATION FOR YOUR REGION AT  
**DIGIKEY.COM/EUROPE**



4.75 MILLION PARTS ONLINE | 650+ INDUSTRY-LEADING SUPPLIERS | 100% AUTHORIZED DISTRIBUTOR

\*A shipping charge of €18.00 (£12.00) will be billed on all orders of less than €65.00 (£50.00). All orders are shipped via UPS for delivery within 1-3 days (dependent on final destination). No handling fees. All prices are in euro and British pound sterling. If excessive weight or unique circumstances require deviation from this charge, customers will be contacted prior to shipping order. Digi-Key is an authorized distributor for all supplier partners. New product added daily. © 2016 Digi-Key Electronics, 701 Brooks Ave. South, Thief River Falls, MN 56701, USA



# Knowledge for the embedded community under the sign of Security of the IoT

Once again this year, the embedded world Conference and the electronic display Conference will be supporting the efficiency and innovative strength of the global embedded industry with first-class specialist knowledge. The focus in 2016 is on the “Internet of Things” and “Security & Safety”. This year’s keynote speakers will be Eugene Kaspersky, CEO Kaspersky Labs and an internationally recognised IT security expert.

Secure communication routes are also a crucial factor for the Internet of Things. Eugene Kaspersky underlines this in his conference keynote speech. He highlights how IT safety aspects are also becoming increasingly relevant in the IoT in the face of the increasing fusion between IT and the embedded world.

For cybersecurity experts, it is particularly difficult to safeguard systems that were not developed with a view to possible security attacks. Kaspersky treats the work of these experts as a type of alchemy without appropriate scientific methods. He calls for the introduction of development standards that will make software inherently more secure. For this, in his opinion, global cooperation is just as essential as the overcoming of barriers to information exchange through the “Balkanisation” of the industry. After all, cybersecurity problems are global and can only be solved by applying global experience. Keynote address will take place on Tuesday 23<sup>rd</sup> from 13:30 to 14:30 in the NCC OST



KEYNOTE  
EUGENE KASPERSKY  
CEO KASPERSKY LAB  
FEBRUARY 23TH, 1:30 PM

The areas covered by the embedded world Conference 2016:

- **Security & Safety for embedded systems:** Securing IoT Devices, A Holistic Approach to Embedded Security, Functional Safety, Secure Software Development Lifecycle
- **Internet of Things:** Connecting Embedded Devices, Embedded Wireless, IoT Architectures, Gateways, Testing & Solutions
- **Software & Systems Engineering:** Requirements Engineering, Standards & Tools, Architecture & Real-Time Aspects, Software Quality, Analysis, Testing & Design, AUTOSAR Beyond Automotive, Ultra Low Power, C/C++ Code – Embedded, Secure & Reliable
- **Hardware Engineering:** Cortex, Multicore, Designing with SoCs and FPGAs
- **Embedded OS:** Embedded Linux, Android, Eclipse, Introduction to Linux-RTOS, GNU/Linux for Safety-Critical Systems
- **Management Focus:** Agile Methods, New Business Opportunities, Open Source Software in Industrial Products

see detailed program on pages 13 & 14



## Contents

- Cover: Microchip
- Page 2: Digi-Key
- Pages 4 - 5: Company profile - FTDI
- Page 6: Company profile - Enclustra
- Page 7: Würth Elektronik
- Pages 8 - 9: EmbeddedWorld Floorplan
- Page 10: Mitsubishi
- Page 10: CML Microcircuits
- Page 11: Rohde & Schwarz
- Pages 12 - 13: EmbeddedWorld Conference Program
- Pages 14 - 15: Company profile - Microchip
- Page 16: Infineon

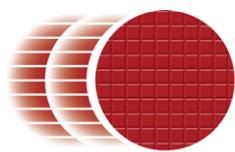
**FTDI  
Chip**
**BRIDGING  
TECHNOLOGIES**

## FTDI Chip - Bridging Technologies

**F**or nearly 25 years FTDI Chip has been developing innovative silicon solutions that enhance the way in which people interact with technology. The principal objective of the company is to 'bridge technologies' by presenting engineers with highly sophisticated, feature-rich, robust and simple-to-use product platforms. These platforms enable the creation of next generation electronic designs delivering a combination of high performance, minimal utilisation of board real estate, low power budgets and very few external components.

FTDI Chip's long-established and continuously expanding Universal Serial Bus (USB) product line boasts such widely recognized product brands as the ubiquitous R-Chip series, plus the X-Chip, Hi-Speed and SuperSpeed USB 3.0 series. In addition to both host and bridge chips, it includes highly-integrated system solutions with built-in microcontroller functionality.

The company's multi award winning Embedded Video Engine (EVE) graphic controller ICs each incorporate display, audio and touch functionality onto a single chip. The unique, streamlined approach utilised by these devices allows dramatic reductions in the development time and bill-of-materials costs involved in advanced Human Machine Interface (HMI) implementation. The first FT80X EVE series has now been joined by the FT81X series, which delivers higher resolution and improved video playback capabilities.

FTDI Chip also provides families of highly-differentiated, speed-optimised microcontroller units (MCUs) with augmented connectivity features, specifically designed to offer compatibility with its USB and EVE product lines. These MCUs (the FT90X and FT51 series) are targeted for key applications where they can add value with their superior processing performance and high levels of operational efficiency.

The company recently launched its latest product, NerO, via KickStarter (pictured). The objective of NerO is to address the fundamental drawbacks of the widely-used Arduino UNO R3 in terms of power delivery. By utilizing the KickStarter crowdfunding platform it has been possible to get the engineering community involved in this project right from the very beginning.

As a fab-less semiconductor company, FTDI Chip partners with the world's leading foundries. The company's headquarters is

located in Glasgow (UK) and is supported with research and development facilities in Glasgow, Singapore and Taipei (Taiwan), plus regional sales and technical support sites in Glasgow, Taipei, Tigard (Oregon, USA) and Shanghai (China).



**FTDI Chip will be exhibiting at Embedded World 2016 (Hall 4A, Stand 326) - with visitors able to learn about its latest production innovations, as well as engaging in interactive demos. Come to our stand and find out how we can help you achieve better designs today.**

### FTDI Chip

Unit 1, 2 Seaward Place  
Centurion Business Park  
Glasgow, G41 1HH  
UK

Tel: +44 (0) 141 429 2777  
E-Mail (Sales): [sales1@ftdichip.com](mailto:sales1@ftdichip.com)  
Website: [www.ftdichip.com](http://www.ftdichip.com)

**Hall 4A, Stand 326**



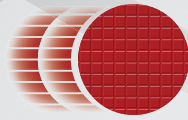

**FTDI  
Chip**

BRIDGING  
TECHNOLOGIES

# **SPEED UP YOUR DESIGN**

*with SuperSpeed USB3.0*

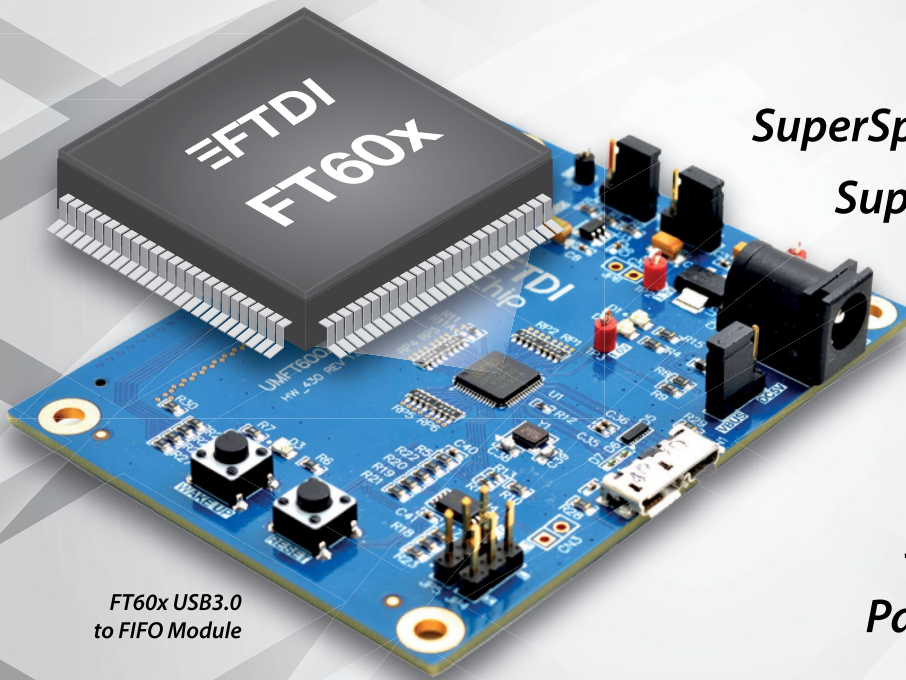

FT60x USB3.0  
to FIFO Module

**Support for  
SuperSpeed USB3.0 (5Gbps)**

**Supports Multi Channel  
FIFO Interface**

**Built-in 16kb FIFO  
Data Buffer Ram**

**Battery Charger  
Detection**

**16-bit or 32-bit Wide  
Parallel FIFO Interface**

**Available in 56 or 76  
Pin QFN Packages**



**[www.ftdichip.com/ft60x](http://www.ftdichip.com/ft60x)**

 **FTDIDesignMadeEasy**

 **@FTDICHIP**

**Visit FTDI Chip on Booth 4A-326 at**

 **embeddedworld2016**  
Exhibition & Conference  
...it's a smarter world

**[www.ftdichip.com/EW2016](http://www.ftdichip.com/EW2016)**



## Enclustra – everything FPGA.

**E**nclustra is an innovative and successful Swiss FPGA design company. With the FPGA Design Center, Enclustra provides services covering the whole range of FPGA-based system development. In the FPGA Solution Center, Enclustra develops and markets highly-integrated FPGA modules and FPGA-optimized IP cores.

Enclustra offers support in every area of FPGA-based system development. Be it high-speed hardware, HDL firmware, embedded software, specification support, implementation, prototype production – or any combination of the above. As a vendor-independent solution provider, Enclustra can help solve the most complex FPGA design challenges whilst delivering a full solution including firmware, hardware, and software. By specialising in forward-looking FPGA technology, and with extremely broad application knowledge, Enclustra can offer ideal solutions at minimal expense in many areas.



The Enclustra Mercury+ SA2, with Altera Cyclone V SoC.

### Reduce time and cost to market with an off-the-shelf module

Enclustra's Altera® and Xilinx® based FPGA and system-on-chip (SoC) modules are developed with the aim of simplifying the overall design of your FPGA-based system, thus significantly reducing the time and cost to market. The SoC modules combine industry standard processor systems with powerful FPGA logic, enabling embedded systems with unmatched performance and flexibility. With 11 different module families and two different form factors, customers have a wide choice of different modules variants, ranging from compact FPGA modules like the Mars ZX2, with the Xilinx Zynq-7020 All Programmable SoC with integrated ARM dual-core processor Cortex-A9, to big-hitters like the Mercury+ SA2, based on the Altera Cyclone® V SoC, which combines 258 user I/Os with a high-performance processor system and many standard interfaces. All Enclustra modules are available in industrial temperature range, and with a planned availability of 10 years. Enclustra also offers a comprehensive ecosystem for its SoC

modules, offering all required hardware, software and support materials. The Enclustra Build Environment allows the end-user to get Linux up and running in minutes; with a few clicks, Linux can be compiled, generating the required U-Boot, Linux and BusyBox-based root file system binaries.



The Mars ZX2 is a complete and powerful embedded processing system.

### Further shorten time to market with IP cores

Enclustra's proven IP Cores provide another way of shortening time to market; the meticulously-tested cores allow customers to fully concentrate their resources on their target application, making the most of their core competencies. Also to this end, Enclustra's FPGA Manager IP solution allows for easy and efficient data transfer between a host and a FPGA over different interface standards like USB 3.0, Gigabit Ethernet and PCI-Express. The solution includes a host software library, an IP core, and any required device controller firmware for an end-to-end data transfer solution. User host applications can communicate with the FPGA through a simple API consisting of simple read/write data commands, hiding the complexity of the underlying protocols. Streaming and memory-mapped accesses are supported.

The Enclustra Universal Drive Controller IP Core enables the easy addition of drive control capabilities to existing or future FPGA designs, removing the need for an extra drive controller chip that would consume precious PCB space and unnecessarily extend the project BOM. Selecting Enclustra's Universal Drive Controller IP Core for the drive control needs of future projects will significantly reduce time to market, as well as the overall system cost.

### Enclustra GmbH

Technoparkstrasse 1  
CH-8005 Zurich - Switzerland  
[sales@enclustra.com](mailto:sales@enclustra.com) - [www.enclustra.com](http://www.enclustra.com)

**Hall 1, Stand 101**



# Stay cool, be **MAPI!**



**#coolMAPI**

***WE speed up  
the future***

embedded world Hall 2 Booth 451

The WE-MAPI is the world's smallest metal alloy power inductor. It's efficiency is unmatched. Available from stock. Samples free of charge. For further information please visit:

[www.we-online.com/WE-MAPI](http://www.we-online.com/WE-MAPI)

Design your DC/DC converter in **REDEXPERT**, the world's most precise software tool to calculate AC losses.

- highest current ratings
- lowest AC losses in class
- incredibly low DCR
- excellent temperature stability
- innovative design
- lowest EMI radiation

The full  
WE-MAPI range:

  
 1.6x1.0    2.0x1.0    2.5x0.6    2.5x0.8    2.5x1.0    2.5x1.2    3.0x1.0    3.0x1.2    3.0x1.5    3.0x2.0    4.0x2.0

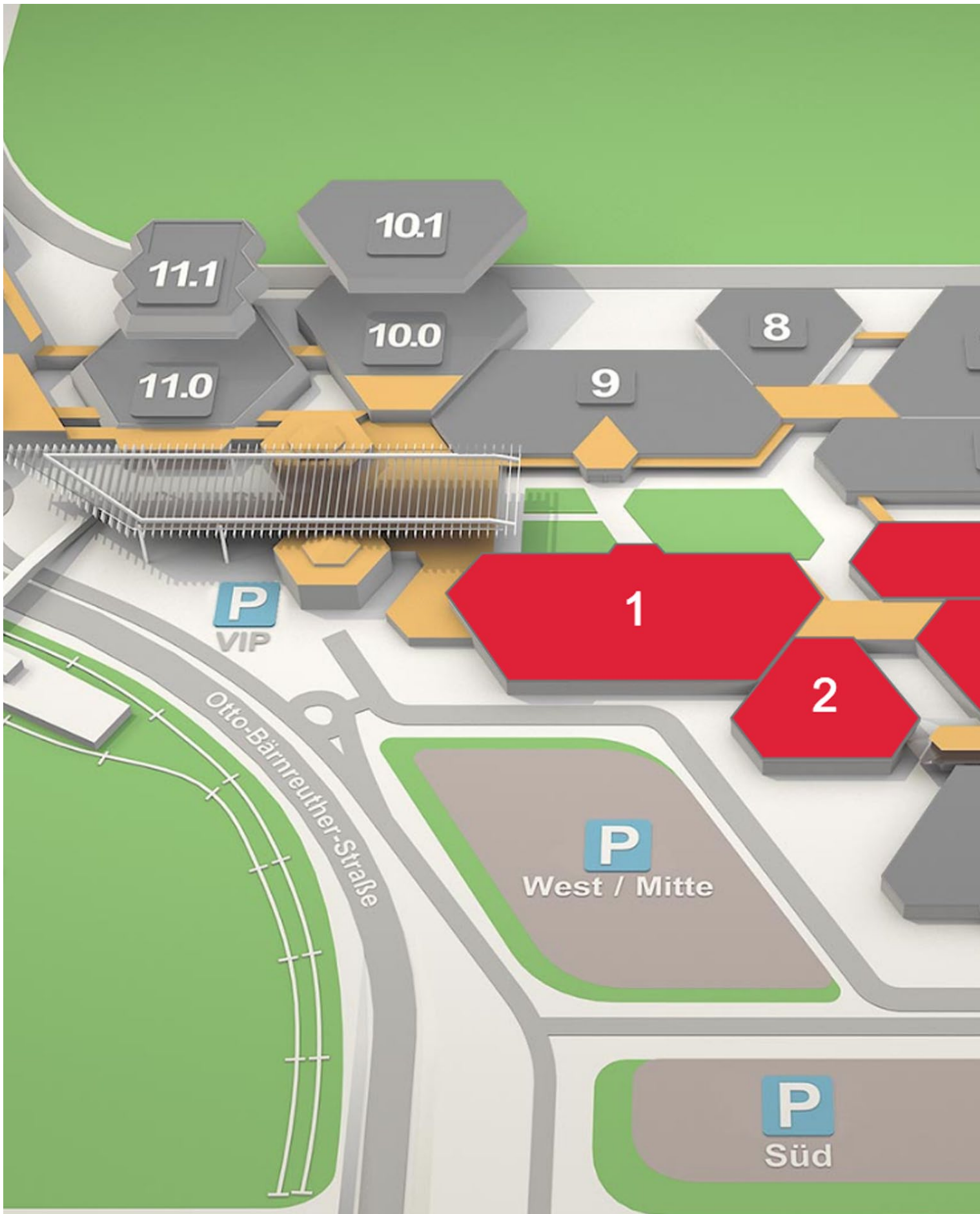



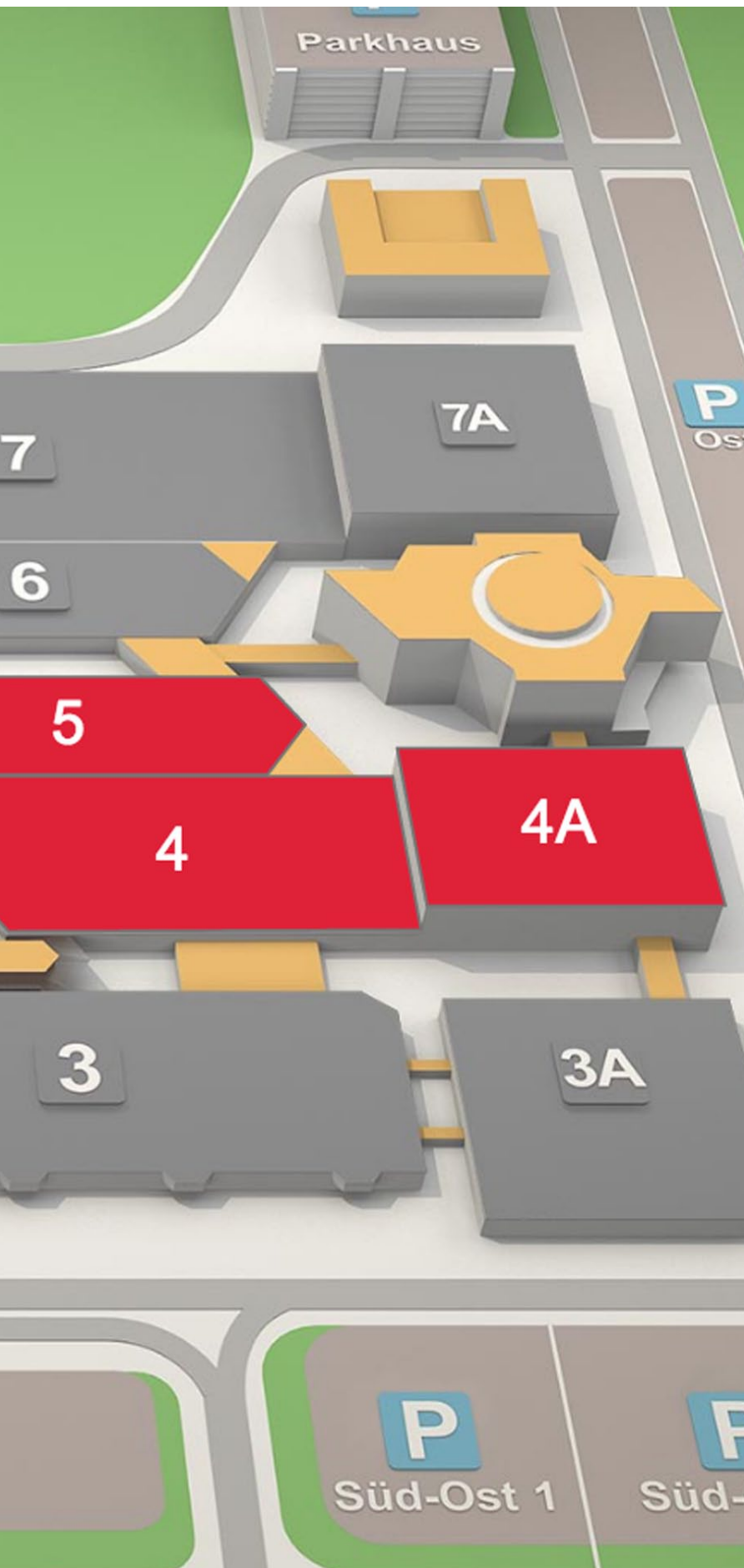

## Visit our partners



Hall 1 - Booth 510



Hall 4A - Booth 326



Hall 4A - Booth 350



Hall 4A - Booth 631



Hall 1 - Booth 181



Hall 2 - Booth 451



Hall 5 - Booth 360



Hall 1 - Booth 101



Hall 4 - Booth 218

# Comms Solutions

From CML Microcircuits



## Wireless Data Modems

- Multi-modulation
- Embedded protocol
- Advanced Coded Modulation (ACM)



## RF Building Blocks ICs

- Direct conversion ICs
- I/Q modulators/demodulators
- Transceivers
- Tx PA linearisation

 CML Microcircuits  
COMMUNICATION SEMICONDUCTORS

Visit [www.cmlmicro.com](http://www.cmlmicro.com)

A CML Microsystems Plc Company

 [www.electronics-eetimes.com](http://www.electronics-eetimes.com) 

 **embeddedworld 2016**  
Exhibition & Conference  
... it's a smarter world



 **Scheme-It**  
FREE Schematic, block or icon diagramming tool for electronic engineers  
[DIGIKEY.COM/SCHEMEIT](http://DIGIKEY.COM/SCHEMEIT)

Visit us at embedded world Hall 2 Booth 645

TFT-LCD Modules

Perfect view –  
in every situation:  
TFT-LCD modules from  
Mitsubishi Electric.

Visit us at the trade fair:  
**embedded world**  
February 23–25, 2016  
Hall 1, booth 181

**Beyond Expectation:** TFT-LCD modules from Mitsubishi Electric set a new standard in the field of industrial use. Designed for high reliability, optimal visibility and enhanced viewing ability even under strong sunlight, Mitsubishi Electric TFT-LCD modules, in combination with our unique PCAP Touch Panel Technology, ensure best performance with excellent picture quality. For this reason professional users choose TFT-LCD modules from Mitsubishi Electric.

More information: [lcd.info@meg.mee.com](mailto:lcd.info@meg.mee.com) / [www.mitsubishichips.eu](http://www.mitsubishichips.eu)

### With Super High Brightness, Glass Bonding and Super Wide Viewing Technology

- Long term support
- Real transfective technology
- Robust mechanical design (up to 6.8 G)
- Wide temperature range (–40 °C up to +85 °C)
- One stop PCAP solution (with integrated controller)
- Super high brightness (up to 1,500 cd/m<sup>2</sup>)
- Special formats (e.g. square, ultrawide)

 **MITSUBISHI ELECTRIC**  
*Changes for the Better*



# From 50 MHz to 4 GHz: Powerful oscilloscopes from the T&M expert.

Visit us at  
hall 4, booth 218

**HD**  
16 bit

**Multi**  
Domain

Fast operation, easy to use, precise measurements.

**R&S®RT02000:** Turn your signals into success. (Bandwidths: 600 MHz to 4 GHz)

**R&S®RTE:** Easy. Powerful. (Bandwidths: 200 MHz to 2 GHz)

**R&S®RTM2000:** Turn on. Measure. (Bandwidths: 200 MHz to 1 GHz)

**R&S®HMO3000:** Your everyday scope. (Bandwidths: 300 MHz to 500 MHz)

**R&S®HMO Compact:** Great Value. (Bandwidths: 70 MHz to 200 MHz)

**R&S®HMO 1002:** Great Value. (Bandwidths: 50 MHz to 100 MHz)

**R&S®Scope Rider:** 2 minutes to be sure. (Bandwidths: 60 MHz to 500 MHz)

All Rohde & Schwarz oscilloscopes incorporate time domain, logic, protocol and frequency analysis in a single device.

Take the dive at [www.scope-of-the-art.com/ad/all](http://www.scope-of-the-art.com/ad/all)



	SECURITY & SAFETY		INTERNET OF THINGS			SOFTWARE &
<b>DAY 1:</b> Tuesday, February 23, 2016	Securing IoT Devices I: Hardware Focus	Class: A Holistic Approach to Embedded Security	Connecting Embedded Devices			Systems Engineering I: Requirements Engineering, Standards & Tools
	Securing IoT Devices II: Automotive Focus					Systems Engineering II: Architecture & Real-Time Aspects
<b>DAY 2:</b> Wednesday, February 24, 2016	Securing IoT Devices III: Communication Focus	Functional Safety	Wireless Technologies	Class: Embedded Wireless – Implementing Tiny Embedded Wireless Solutions	Internet of Things I: IoT Overview	Software Engineering I: Software Quality
	Securing IoT Devices IV: Industrial Focus					Internet of Things II: IoT Architectures, Gateways & Testing
<b>DAY 3:</b> Thursday, February 25, 2016	Securing IoT Devices V: Parry Attacks	Class: The Secure Software Development Lifecycle	Bus Systems & Network Technologies		Internet of Things III: IoT Solutions	Class: AUTOSAR beyond Automotive
	Securing IoT Devices VI: Platforms & Layers					Class: With Open Source to an IoT Sensor

## KEYNOTE-SPEAKERS



**Eugene Kaspersky, Kaspersky Lab**

**Conference Keynote:** The Long Hard Road Out of the Cyber Dark Ages  
 February 23rd, 1:30 PM

Eugene Kaspersky is a world-renowned cybersecurity expert and successful entrepreneur. He is the chairman and CEO of Kaspersky Lab, the world's largest privately-held vendor of endpoint protection and cybersecurity solutions. Eugene began his career in cybersecurity accidentally when his computer became infected with the 'Cascade' virus in 1989. Eugene's specialized education in cryptography helped him analyze the encrypted virus, understand its behavior, and then develop a removal tool for it. In 1997 Eugene and a group of associates founded Kaspersky Lab, which now has more than 3000 employees and operates all over the world.



**Dr. Alexander Lautz, Deutsche Telekom**

**Keynote:** The Next Decade of IoT Networks  
 February 24th, 9:30 AM

Alexander Lautz is currently Senior Vice President M2M at Deutsche Telekom. In this role, he has the overall responsibility for the group-wide M2M business at Deutsche Telekom. Mr. Lautz joined T-Mobile Deutschland GmbH in 2002, first as Head of Business Marketing, before taking over as Head of Consumer Marketing in 2004. When Deutsche Telekom launched congstar as its second brand in Germany in 2007, Mr. Lautz took over as Managing Director of the newly founded company. In 2011, he moved to T-Systems International GmbH, where he was responsible for implementing innovative B2B2C products and solutions within the business units Connected Car and later Connecting Customers. Before his career at Deutsche Telekom, Mr. Lautz held different management positions at both CNI GmbH and Mannesmann Arcor AG and was Managing Director of an IP provider for business customers.



## CONFERENCE PROGRAM

SYSTEMS ENGINEERING		HARDWARE ENGINEERING	EMBEDDED OS			MANAGEMENT FOCUS
Ultra Low Power		Cortex	Embedded OS I: Make Your Choice		The Mc Guire Classes I: Introduction to Linux-RTOS (PREEMPT_RT)	Management Focus I: Agile Methods
	The Greg Davis Classes I: Writing Embedded C/C++ Code	Multicore	Embedded OS II: Android			Management Focus II: New Business Opportunities
		Designing with SoCs and FPGAs	Embedded Linux	Class: Model-based Software Development Based on Eclipse	The Mc Guire Classes II: GNU/Linux for Safety-Critical Systems	
	The Greg Davis Classes II: Tools, Techniques & Rules for Secure & Reliable C/C++ Code					
Class: Ultra Low Power Workshop				Class: Embedded Android Workshop	Class: Introduction to Embedded Linux – a Short Crash Course	The Mc Guire Classes III: Legal Aspects of Using Open Source Software in Industrial Products
	The Greg Davis Classes III: A View into Greg's Toolbox – Methods & Advanced Optimization					

## STEERING BOARD



**Prof. Dr. Helmut Beikirch**  
University of Rostock  
Institute of Electronic  
Appliances and Circuit



**Dr. Klaus Grimm**



**Caspar Grote**  
DESIGN&ELEKTRONIK



**Prof. Dr. Axel Sikora**  
University of Applied  
Sciences Offenburg



**Prof. Dr. Matthias Sturm**  
Conference Chair  
HTWK Leipzig  
Fakultät Elektrotechnik  
und Informationstechnik

## Microchip launches free, cloud-based development platform; providing an easy way to get started with PIC® MCUs

Microchip announces its MPLAB® Xpress Cloud-based Integrated Development Environment (IDE). This online development platform is the easiest way to get started with PIC® microcontrollers (MCUs), with zero downloads, sign-in or setup needed to start designing. Microchip's free, cloud-based IDE brings the most popular features of the award-winning MPLAB X IDE to Internet-connected PCs, laptops or tablets. MPLAB Xpress offers the industry's most comprehensive feature set, including a library of Microchip-validated code examples, interface to MPLAB Code Configurator (MCC) 3.0 for GUI-based MCU peripheral setup and automatic code generation, integrated MPLAB XC compilers, support for programmer/debugger hardware, and 10 GB of secure online storage with a myMicrochip account. Users can easily migrate their projects to the full, downloadable MPLAB X IDE. Additionally, the MPLAB Xpress Community enables developers to share their code, design ideas and knowledge.

Cloud-based hardware development is supported by connecting any USB-enabled PC, laptop or tablet to tools such as the MPLAB Xpress Evaluation Board. This development board features an integrated programmer, a PIC16F18855 MCU and a mikroBUS™ header for system expansion with MikroElektronika's more than 180 Click™ boards. The MPLAB Xpress IDE also supports Microchip's Curiosity Development Board, a cost-effective tool with integrated programmer and debugger, as well as expansion options for add-on boards and external connectivity. Additionally, this online IDE can be used with Microchip's popular PICKit™ 3 In-Circuit Debugger/Programmer, which provides programming and debugging capabilities for over 1,000 PIC MCUs.

The Web-based MPLAB Xpress reduces the installation time to zero while enabling users to build an entire application within minutes. Users can open a browser and quickly generate code via the integrated MPLAB Code Configurator which integrates with MPLAB Xpress: this is a feature which is not available with any other cloud-based IDE. Users can then test that code with the included simulator, compile the code and then programme and debug their target MCU.

### Key Facts:

- ▶ MPLAB® Xpress IDE is the industry's most comprehensive online development environment
- ▶ Only cloud-based IDE with integrated Code Configurator
- ▶ Hardware development with any USB-enabled PC, laptop or tablet via Microchip's MPLAB Xpress Evaluation Board
- ▶ Designers can create an application, simulate, compile code, programme and debug an MCU
- ▶ No downloads, sign-in or setup required to start designing

The MPLAB Xpress Community allows users to get their project started quickly, solve problems, and inspire others by sharing ideas and knowledge. The "Examples" section provides easy, searchable access to MCU code developed and validated by Microchip engineers, such as setup, basic functions and advanced projects. Designers can add to this knowledge base by making any of their stored projects accessible to the rest of the user community. To facilitate further discussion and collaboration, a dedicated MPLAB Xpress User Forum and Wiki are also available.

To access MPLAB Xpress; view getting-started and application demo videos; request one of a limited number of free MPLAB Xpress Evaluation Boards; or to find additional information, visit **Microchip's Embedded World booth (Hall 1: Booth 1-510)**

### Get started in 3 easy steps with Test Drive mode

1. **Access** Microchip validated Code Examples (**no sign-in**)
2. **Edit** your code; simulate, and compile...
3. **Program** the MPLAB Xpress Evaluation Board

[MPLABXpress.microchip.com](http://MPLABXpress.microchip.com)







## MPLAB® Xpress

Cloud Based Development Platform

### The easiest way to get started with PIC® MCUs...

Industry's most comprehensive online development platform includes

- Most popular features of the award winning MPLAB X IDE
- MPLAB Code Configurator 3.0 – GUI based code generation, not available on any other cloud based tool
- Library of Microchip-validated code examples to get you started
- Integrated MPLAB XC compilers
- MPLAB Xpress Community enables developers to share code, design ideas, and knowledge
- Support for Microchip's most popular hardware tools – PICKIT™ 3 and Curiosity Development Board

Free MPLAB Xpress Evaluation Board... Limited Quantities Available  
[MPLABXpress.microchip.com](http://MPLABXpress.microchip.com)



## MPLAB® Xpress

Additional Features with Free Account

### Login with your FREE myMicrochip account, and

- **Set up** your MCU with MPLAB Code Configurator
- **Debug** with additional hardware tools
- **Get** 10GB of secure online storage
- **Save** your code in the cloud and access it anywhere
- **Participate** in the MPLAB Xpress Community



[MPLABXpress.microchip.com](http://MPLABXpress.microchip.com)



## Easy Migration to MPLAB® X

### Enjoy full project compatibility with MPLAB X

Advanced development features in MPLAB X include:

- Code templates for fast editing of common code frameworks
- Advanced debugging features
- Ability to track code change history
- Command line tools for programming and debugging

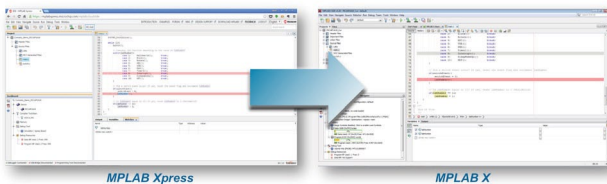

## MPLAB® Xpress

Cloud Based Development Platform

### Get started NOW with PIC® MCUs

Go to <https://mplabxpress.microchip.com>

1. **Access** Microchip validated Code Examples (*no sign-in*)
2. **Edit** your code; simulate, and compile...
3. **Program** the MPLAB Xpress Evaluation Board

Experience the industry's most comprehensive cloud based development environment

[MPLABXpress.microchip.com](http://MPLABXpress.microchip.com)



# Free Your Creativity

with Core Independent Peripherals

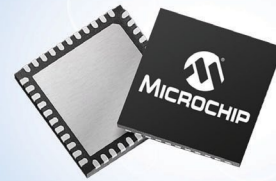

**FLEXIBLE INTELLIGENCE MADE EASY**  
 8-BIT PIC® MICROCONTROLLERS

PIC® microcontrollers with Core Independent Peripherals take 8-bit MCU performance to a new level. With a number of on-board modules designed to increase capability in any control system, these MCUs represent the best value in embedded design.

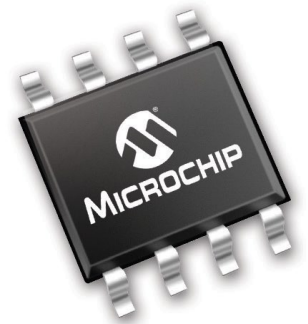

Core Independent Peripherals are designed to handle their tasks with no code or intervention from the CPU to maintain operation. As a result, they both simplify the implementation and boost the performance of complex control systems while giving designers the flexibility to innovate.

### Flexible Functional Building Blocks

- ▶ Power conversion
- ▶ Motor drive
- ▶ Signal generation
- ▶ Sensor interface



[www.microchip.com/get/eucip](http://www.microchip.com/get/eucip)

The Microchip name and logo, the Microchip logo and PIC are registered trademarks of Microchip Technology Incorporated in the U.S.A. and other countries. All other trademarks are the property of their registered owners. © 2016 Microchip Technology Inc. All rights reserved. MEC2057Eng02.16



# Infineon's solution for automatic opening systems

Enabling benchmark efficiency for your application



At present, every building utilizes opening systems at numerous positions in and around. These openings are equipped with different systems to manage various actions based on their task.

Infineon offers a full system solution for opening systems, making applications more energy efficient and assisting to secure against unauthorized manipulation of firmware update. Incorporated products are smart sensors, motor controls, supplies and battery management, which help to reduce energy losses in all conditions. Our radar solutions cover a 16 times larger area than common infrared solutions.

## Key highlight products:

- › OptiMOS™ and StrongIRFET™ Power MOSFETs 20 V-300 V – a powerful combination
- › CIPOST™ – integrated motor drive solutions enabling cost efficient designs
- › 600 V CoolMOS™ P6 Power MOSFETs – ease-of-use and superior efficiency for your SMPS application



To learn more about Infineon's system solution please visit:  
[www.infineon.com/automaticopeningsystem](http://www.infineon.com/automaticopeningsystem)

